

**POWER STEERING BOX**

Remove and refit

Service tools:  
Drop arm extractor-MS252A

**NOTE:** It is important that whenever any part of the system, including the flexible piping, is removed or disconnected, that the utmost cleanliness is observed.

All ports and hose connections should be suitably sealed off to prevent ingress of dirt, etc. If metallic sediment is found in any part of the system, the complete system should be checked, the cause rectified and the system thoroughly cleaned.

Under no circumstances must the engine be started until the reservoir has been filled. Failure to observe this rule will result in damage to the pump.

Metric pipe fittings are used with 'O' ring pipe ends on the fittings to the steering box.

Follow normal 'O' ring replacement procedure whenever pipes are disconnected.

Ensure that compatible metric components are used when fitting replacement pipes.

**CAUTION:** PRIOR TO REMOVING ANY OF THE COMPONENTS INCORPORATED IN THE STEERING LINKAGE, IT IS IMPERATIVE THAT THE ROAD WHEELS ARE IN A STRAIGHT AHEAD POSITION AND THAT THE STEERING WHEEL IS THEN REMOVED TO PREVENT THE CRUISE CONTROL SPIRAL CASSETTE BEING WOUND UP OR DAMAGED IF THE STEERING LINKAGE IS INADVERTENTLY MOVED OR ROTATED.

**AFTER REFITTING STEERING LINKAGE COMPONENTS, THE ROAD WHEELS MUST BE RE-POSITIONED STRAIGHT AHEAD BEFORE FITTING THE STEERING WHEEL, DO NOT RECONNECT THE MULTI-PLUG TO THE CASSETTE OR FIT THE TRIM PAD AT THIS STAGE. IF, AFTER THE VEHICLE HAS BEEN DRIVEN, IT IS FOUND THAT THE STEERING WHEEL REQUIRES RE-POSITIONING, REMOVE THE WHEEL. RE-ALIGN THE DRIVE PEGS ON THE CRUISE CONTROL CASSETTE BY SLIGHTLY ROTATING THE UPPER PART OF THE CASSETTE IN THE APPROPRIATE DIRECTION UNTIL THE PEGS LIE HORIZONTAL TO THE STEERING COLUMN.**

**FIT THE STEERING WHEEL ENSURING THAT THE DRIVE PEGS LOCATE IN THEIR RESPECTIVE HOLES ON THE REAR OF THE STEERING WHEEL.**

**AFTER FINAL ALIGNMENT RECONNECT THE MULTI-PLUG TO THE CASSETTE, TIGHTEN THE STEERING WHEEL SECURING NUT AND FIT THE TRIM PAD.**

**Removing**

1. Park the vehicle on a level surface.
2. Prop open the hood.
3. Remove the filler cap from the power steering fluid reservoir.
4. Disconnect the fluid pipes from the pump. Drain and discard the fluid. Replace the filler cap.
5. Disconnect the fluid feed and return pipes from the steering box.

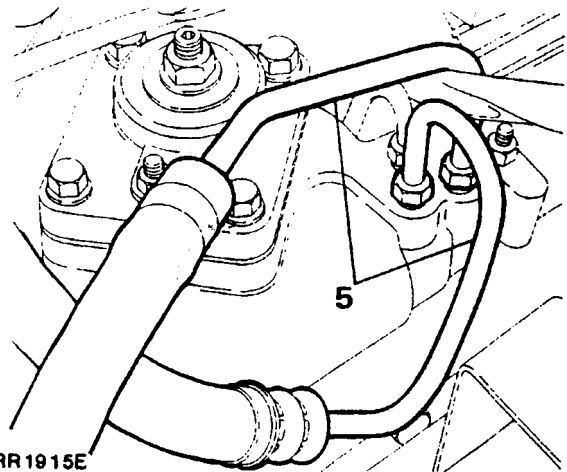

6. Seal all disconnected hose connections to prevent ingress of foreign matter.
7. Jack up and support the chassis front end with axle stands. Alternatively, raise the vehicle on a hoist.

**WARNING:** Whichever method is adopted, it is essential that the wheels are chocked, the parking brake is applied, and low range selected with differential lock engaged.

Continued-'

8. Disconnect the drag link from the drop arm using a suitable extractor.
9. Remove the drop arm, using drop arm extractor MS252A.
10. Remove the pinch bolt attaching the universal joint to the power steering box.
11. Loosen the nut securing the tie bar to the chassis.
12. Remove the bolts securing the tie bar to the steering box and move the tie bar aside.
13. Remove the fixings attaching the power steering box to the chassis side member.
14. Withdraw the power steering box.

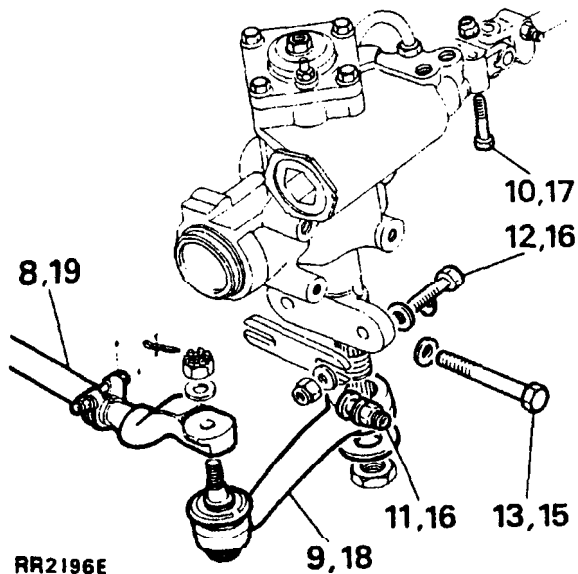

RR2196E

## Refitting

15. Refit the steering box to the chassis side member and tighten the four Nyloc nuts to the correct torque (see section 06-Torque values).
  16. Refit the tie bar to the steering box, and tighten the tie bar securing nut to the correct torque (see section 06-Torque values).
  17. Reconnect the pinch bolt, attaching the universal joint to the power steering box, and tighten to the correct torque (see section 06-Torque values).
  18. Refit the drop arm.
  19. Refit the drag link and secure.
  20. Lower the vehicle to ground level.
  21. Remove the sealing plugs and reconnect the flexible hoses to the steering box.
  22. Remove the sealing plug and refit the flexible hose to the power steering pump.
  23. Ensure that the steering wheel is correctly aligned when the wheels are in the straight-ahead position.
- NOTE:** It may be necessary to remove the steering wheel and reposition on the splines to obtain this condition. See steering wheel- remove and refit.
24. Remove the filler cap from the power steering fluid reservoir. Fill the reservoir to the oil level mark ON the dipstick attached to the filler cap with the recommended fluid (see Section 09) and bleed the power steering system. See power steering system-bleed.
  25. Check the fluid level and replace the filler cap.
  26. Check, and if necessary, adjust the steering box.
  27. Test the steering system for leaks, with the engine running, by holding the steering hard on full lock in both directions.
- CAUTION:** Do not maintain this pressure for more than 30 seconds in any one minute, to avoid causing the oil to overheat and possible damage to the seals.
28. Close the hood.
  29. Road test the vehicle.

POWER STEERING BOX OVERHAUL

Service tools:

- LST120 -'C' Wrench
- LST119 -Worm adjusting wrench
- MS252A -Drop arm extractor
- 606602 -Ring expander
- 606603 -Ring compressor
- 606604 -Seal saver, sector shaft
- RO1015 -Seal saver, valve and worm
- RO1016 -Torque setting tool

Dismantle

1. Remove the steering box from the vehicle, and withdraw the drop arm.

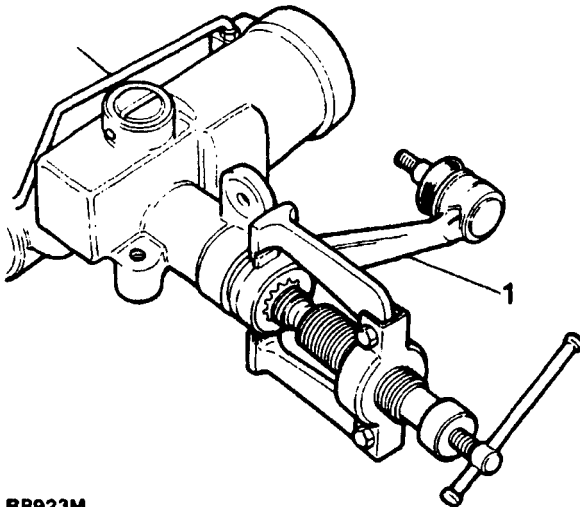

RR923M

2. Rotate the retainer ring, as necessary, until one end is approximately 12 mm (0.500 in) from the extractor hole.
3. Lift the cover retaining ring from the groove in the cylinder bore, using a suitable pointed drift applied through the hole provided in the cylinder wall.
4. Complete the removal of the retainer ring, using a screwdriver.
5. Turn on left lock until the piston pushes out the end cover.

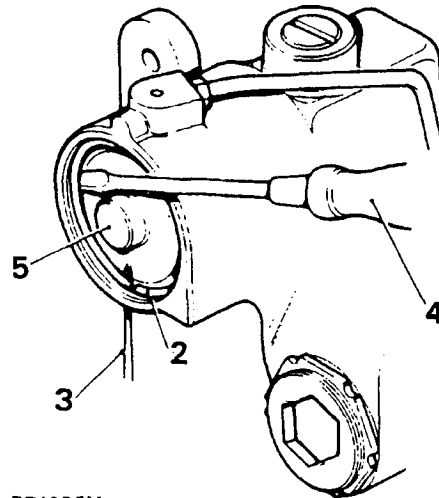

RR1695M

6. Loosen the set screw retaining the rack pad adjuster.
7. Remove the rack pad adjuster.
8. Remove the sector shaft adjuster locknut.
9. Remove the sector shaft cover fixings.
10. Screw in the sector shaft adjuster until the cover is removed.
11. Slide out the sector shaft.

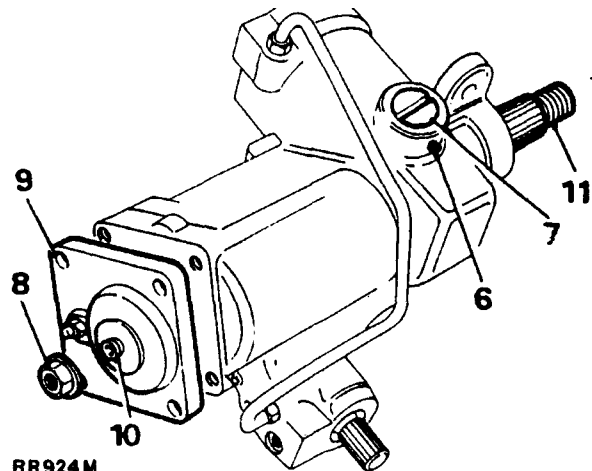

RR924M

12. Withdraw the piston, using a suitable bolt screwed into the tapped hole in the piston.

Continued

- 13. Remove the worm adjuster locknut using 'C' Wrench, LST1 20.
- 14. Remove the worm adjuster using wrench LST119.

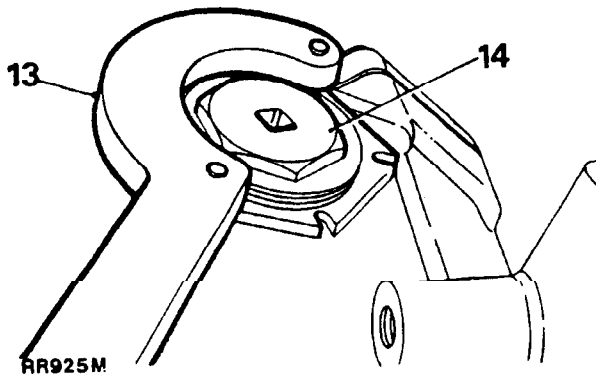

- 21. Remove the circlip and seals from the input shaft housing bore.

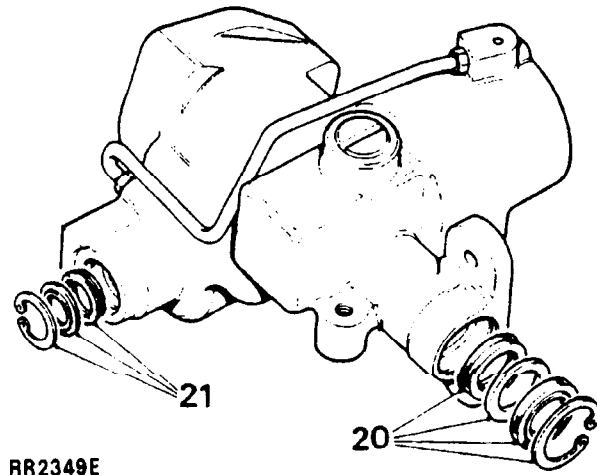

- 15. Tap the splined end of the shaft to free the bearing.
- 16. Withdraw the bearing cup and caged ball bearing assembly.
- 17. Withdraw the valve and worm assembly.
- 18. Withdraw the inner bearing ball race and shims.
- 19. Retain the shims for reassembly

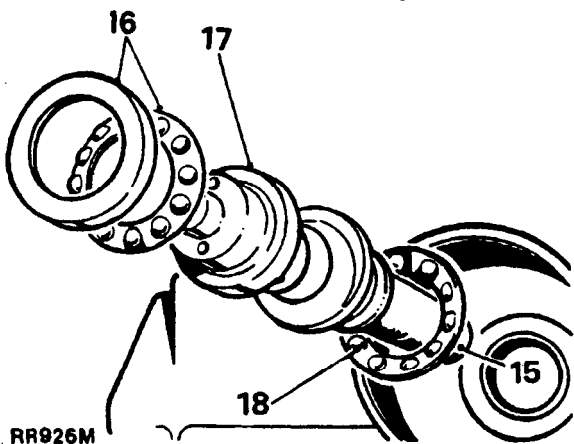

**Inspecting**

- 22. Discard all rubber seals and provide replacements.

**NOTE:** A rubber seal is fitted behind the plastic ring on the rack piston. Discard the seal and also the plastic ring and provide replacements.

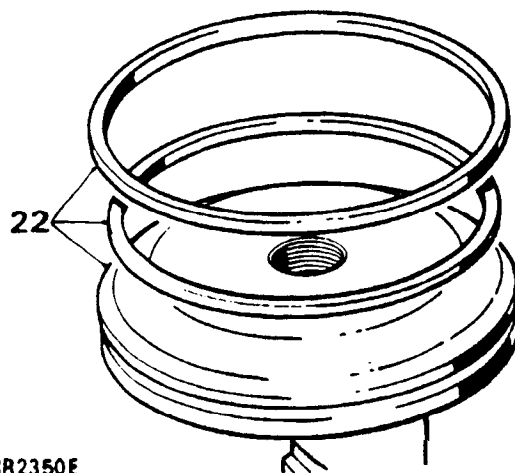

**Steering box seals**

- 20. Remove the circlip and seals from the sector shaft housing bore.

**NOTE:** Do not remove the sector bushes from the casing, Replacement parts are not available.

**Steering box casing**

- 23. Examine the piston bore for traces of scoring and wear.
- 24. Examine the inlet tube thread for damage. If repair is necessary this can be undertaken by using a suitable tap.
- 25. Examine the feed tube for signs of cracking.

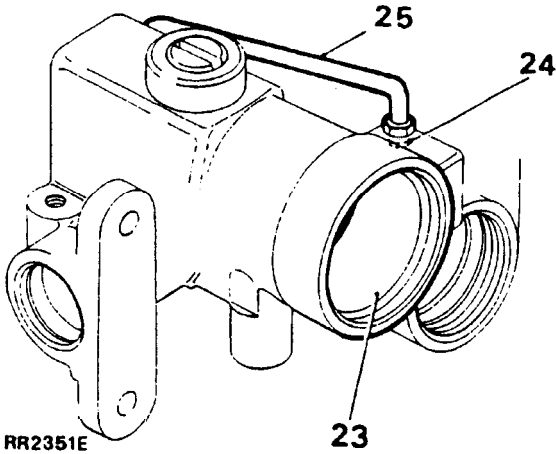

**Sector shaft assembly**

- 26. Check that there is no side play on the rollers.
- 27. If excessive side play on the roller does exist fit a new sector shaft.
- 28. Check the condition of the adjuster screw threads.
- 29. Examine the bearing areas on the shaft for excessive wear.
- 30. Examine the gear teeth for uneven or excessive wear.

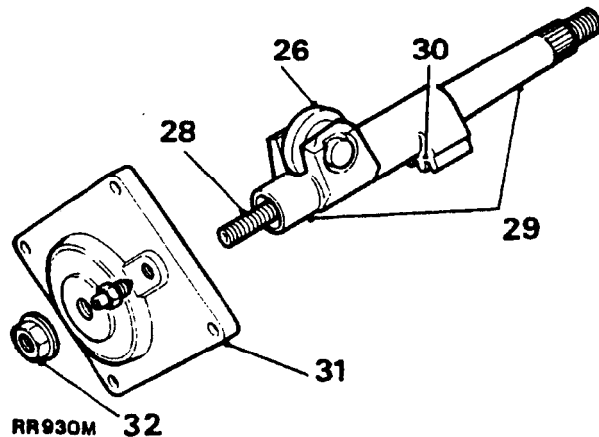

**Sector shaft cover assembly**

- 31. The cover, bush and seat are supplied as a complete assembly for replacement purposes.

**Sector shaft adjuster locknut**

- 32. The locknut functions also as a fluid seal, a new nut be fitted at overhaul.

**Valve and worm assembly**

- 33. Examine the valve rings which must be free from cuts, scratches and grooves. The valve rings should be a loose fit in the valve grooves.
- 34. Remove the damaged rings ensuring that no damage is done to the seal grooves.
- 35. If required, fit replacement rings, using the ring expander 606602. Warm the rings and expander tool to aid assembly, using hot water for this purpose. Fit the rings to the expander, slide the expander over the valve and worm assembly, in turn fit the rings to their respective grooves. Remove the expander, slide the valve and worm assembly into the ring compressor 606603 and allow the rings to cool.

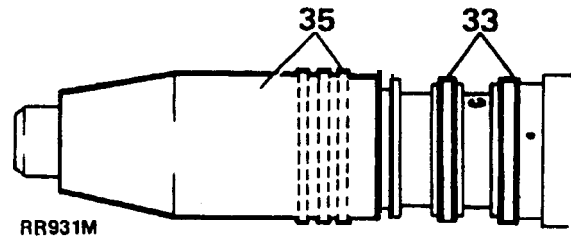

**NOTE:** The expander will not pass over rings already fitted. The rings must be discarded to allow access and then new rings must be fitted.

Continued

- 36. Examine the bearing areas for wear. The areas must be **smooth and not** indented.
- 37. Examine the worm track which must be smooth and not indented.
- 38. Check for wear on the torsion bar assembly pins; no free movement should exist between the input shaft and the worm.

**NOTE:** Any sign of wear makes it essential that a new valve and worm assembly is fitted.

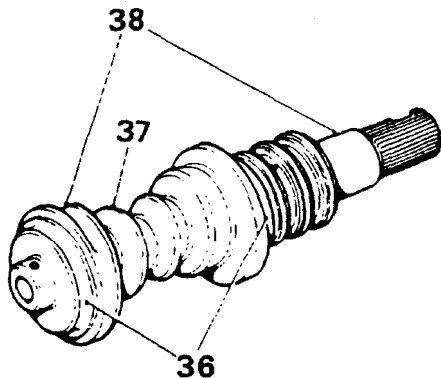

RR932M

**Ball bearing and cage assemblies**

- 39. Examine the ball races and cups for wear and general condition.
- 40. If the ball cage has worn against the bearing cup, fit replacements.
- 41. Bearing balls must be retained by the cage.
- 42. Bearings and cage repair are carried out by the complete replacement of the bearings and cage assembly.

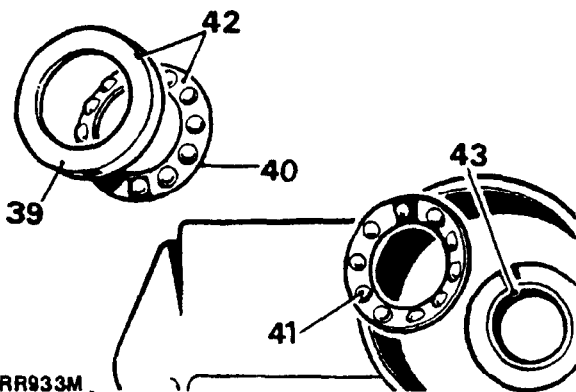

RR933M

- 43. To remove the inner bearing cup and shim washers, jar the steering box on the work bench, or use a suitable extractor.

**NOTE:** Should difficulty be experienced at this stage, warm the casing and the bearing assembly. Cool the bearing cup using a suitable mandrel and jar the steering box on the bench.

**Rack thrust pad and adjuster**

- 44. Examine the thrust pad for scores.
- 45. Examine the adjuster for wear in the pad seat.
- 46. Examine the nylon pad for distortion and adjuster set screw assembly for wear.

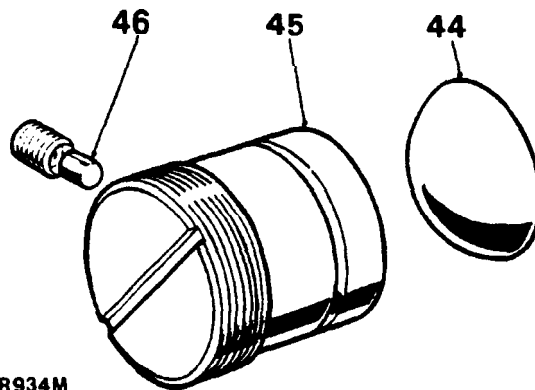

RR934M

**Rack and piston**

- 47. Examine for excessive wear on the rack teeth.
- 48. Ensure the thrust pad bearing surface is free from scores and wear.
- 49. Ensure that the piston outer diameters are free from burrs and damage.
- 50. Examine the seal and ring groove for scores and damage.

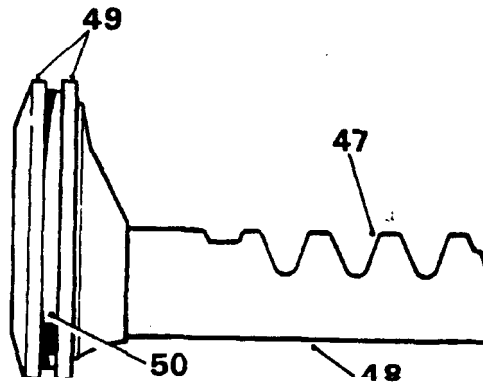

RR935M

51. Fit a new rubber ring to the piston. Warm the white nylon seal and fit this to the piston.
52. Slide the piston assembly into the cylinder with the rack tube outwards. Allow to cool.

**Reassemble**

**NOTE:** When fitting replacement oil seals, these must be lubricated with recommended fluid. Also ensure that absolute cleanliness is observed during assembly.

**Input shaft oil seal**

53. Fit the seal, lipped side first, into the housing. When correctly seated, the seal backing will lie flat on the bore shoulder.
54. Fit the extrusion washer and secure with the circlip.

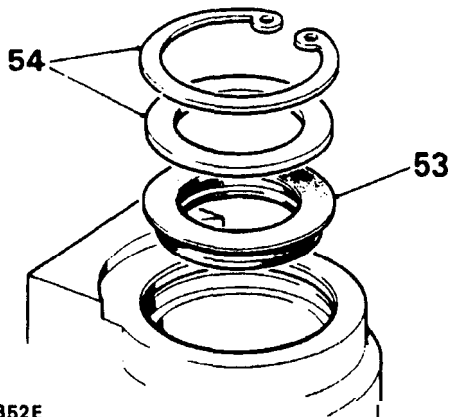

RR2352E

**Sector shaft seal**

55. Fit the oil seal, lipped side first.
56. Fit the extrusion washer.
57. Fit the dust seal, lipped side last.
58. Fit the circlip.

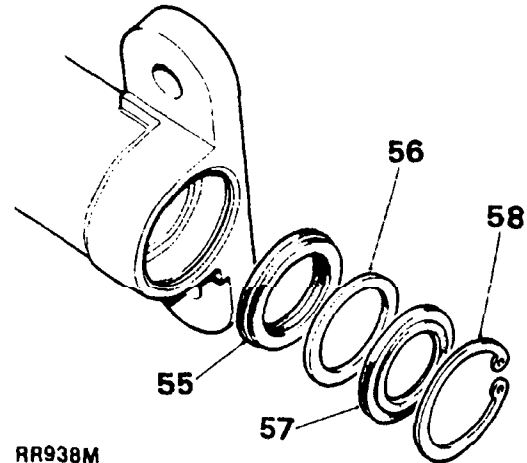

RR938M

**Fitting the valve and worm assembly**

59. If removed, refit the original shim washer(s) and the inner bearing cap. Only Petroleum Jelly may be used as an aid to assembling the bearings.

**NOTE:** If the original shims are not available, fit shim(s) of 0.76 mm (0.030 in) nominal thickness.

Continued

60. Fit the inner cage and bearings assembly.
61. Fit the valve and worm assembly, using seal saver RO1015 to protect the input shaft seal.
62. Fit the outer cage and bearings assembly.
63. Fit the outer bearing cup.

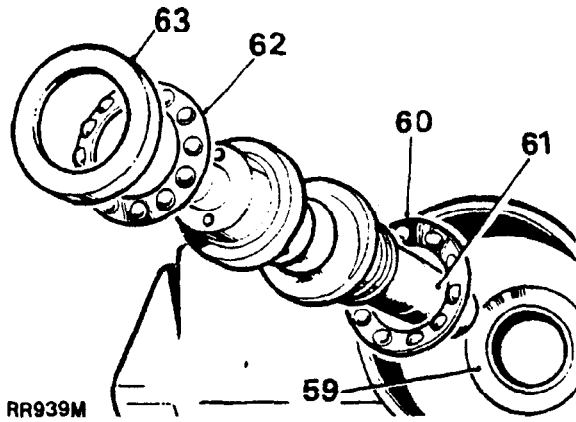

64. Fit a new worm adjuster sealing ring and loosely screw the adjuster into the casing. Fit the locknut, but do not tighten.
65. Turn in the worm adjuster until the end-float at the input is almost eliminated.
66. Measure and record the maximum rolling distance of the valve and worm assembly, using a spring balance and cord coiled around the torque setting tool RO1016.
67. Turn in the worm adjuster to increase the figure recorded in instruction 66 by 1.8 to 2.2 kg (4 to 5 lb) at 1.250 in (31.7 mm) radius to settle the bearings, then back off the worm adjuster until the figure recorded in instruction 66 is increased by 0.9 to 1.3 kg (2 to 3 lb) only, with locknut tight. Use worm adjusting wrench LST119 and 'C' wrench LST1 20.

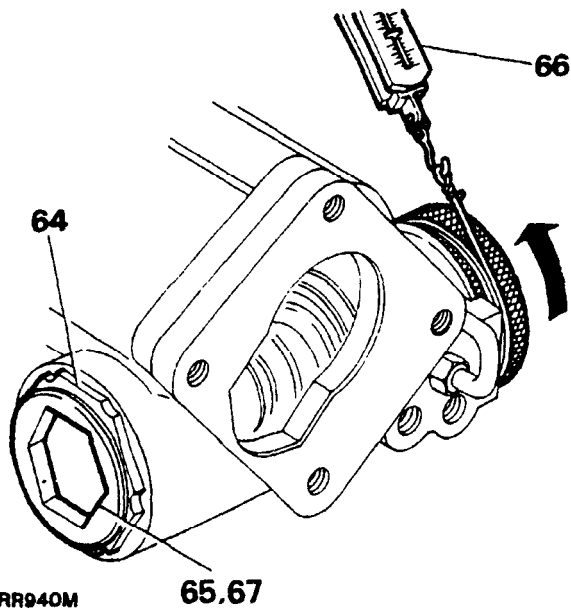

**Fitting the rack and piston**

68. Screw a slave bolt into the piston head for use as an assembly tool.
69. Fit the piston and rack assembly so that the piston is 63.5 mm (2.5 in) approximately from the outer end of the bore.
70. Feed in the sector shaft using seal saver 606604 aligning the centre gear pitch on the rack with the centre gear tooth on the sector shaft. Push in the sector shaft, and, at the same time rotate the input shaft about a small arc to allow the sector roller to engage the worm.

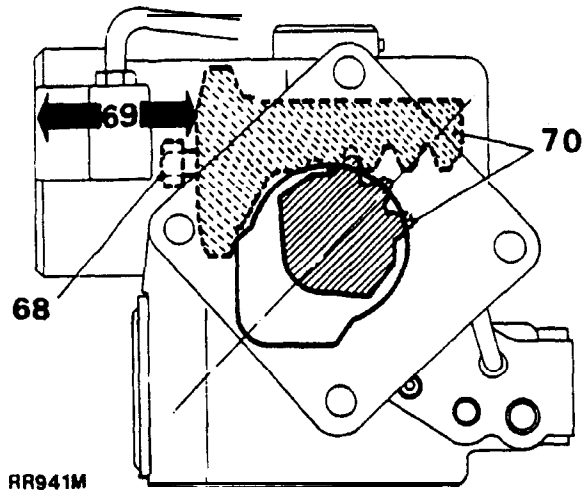



**Fitting the rack adjuster**

- 71. Fit the sealing ring to the rack adjuster.
- 72. Fit the rack adjuster and thrust pad to engage the rack. Back off a half turn on the adjuster.
- 73. Loosely fit the nylon pad and adjuster set screw assembly to engage the rack adjuster.

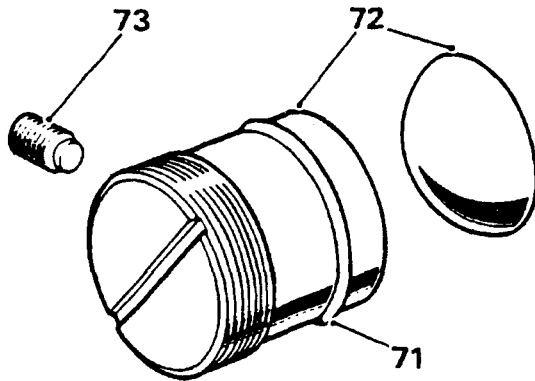

RR942M

**Fitting the sector shaft cover**

- 74. Fit the sealing ring to the cover.
- 75. Screw the cover assembly fully on to the sector shaft adjuster screw.
- 76. Position the cover on to the casing.
- 77. Tap the cover in place. It necessary back off on the sector shaft adjuster screw to allow the cover to joint fully with the casing.

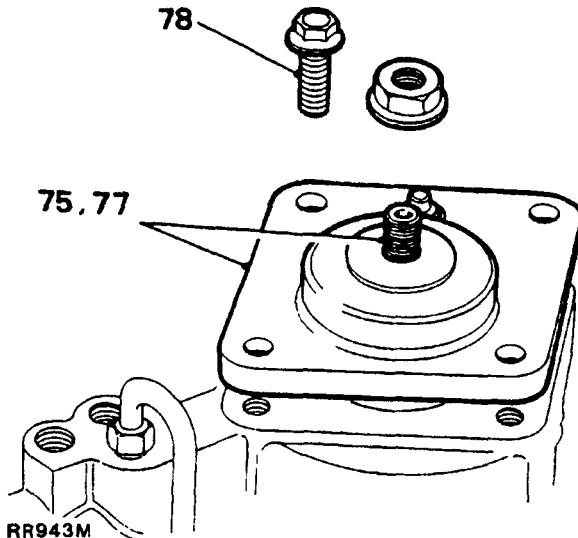

**NOTE:** Before tightening the fixings, rotate the input shaft about a small arc to ensure that the sector roller is free to move in the valve worm.

- 78. Fit the cover fixings and tighten to the correct torque (see section 06-Torque values).

**Fitting the cylinder cover**

- 79. Fit the square section seal to the cover.
- 80. Remove the slave bolt fitted at operation 68 and press the cover into the cylinder just sufficient to clear the retainer ring groove.
- 81. Fit the retainer ring to the groove with one end of the ring positioned 12 mm (0.5 in) approximately from the extractor hole.

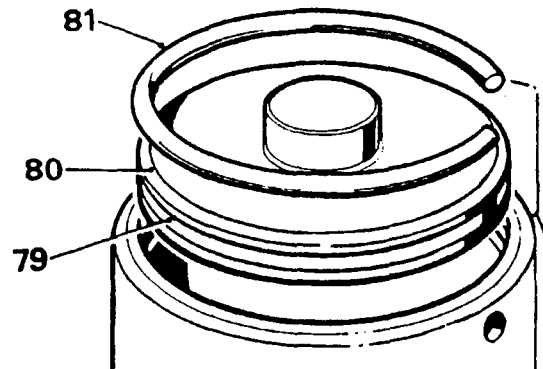

RR944M

Continued

### Adjusting the sector shaft

82. Set the worm on centre by rotating the input shaft half the total number of turns from either lock.
83. Rotate the sector shaft adjusting screw counter-clockwise to obtain backlash between the input shaft and the sector shaft.
84. Rotate the sector shaft adjusting screw clockwise until the backlash is just eliminated.
85. Measure and record the maximum rolling resistance at the input shaft, using a spring balance, cord and torque tool **RO1016**.
86. Hold the sector shaft adjuster screw and loosely tit a new locknut.
87. Turn in the sector shaft adjuster screw until the figure recorded in instruction 85 is increased by 0.9 to 1.3 kg (2 to 3 lb) with the locknut tightened.

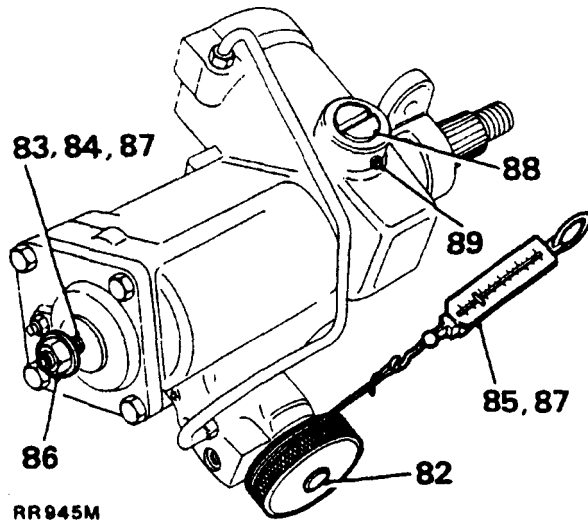

### Adjusting the rack adjuster

88. Turn in the rack adjuster to increase the figure recorded in instruction 87 by 0.9 to 1.3 kg (2 to 3 lb). **The final figure may be less than 7.25 kg (16 lb) but must not exceed this figure.**
89. Lock the rack adjuster in position with the set screw.

### Torque peak check

With the input shaft rotated from lock-to-lock, the **rolling resistance** torque figures should be greatest across the centre position (1.5 turns approximately from full lock) and equally disposed about the centre position.

The condition depends on the value of shimming fitted between the valve and worm assembly inner bearing cup and the casing. The original shim washer value will give the correct torque peak position unless major components have been replaced.

### Procedure

90. With the input coupling shaft toward the operator, turn the shaft fully counter-clockwise.
91. Check the torque figures obtained from lock-to-lock using a spring balance cord and torque tool R01016.

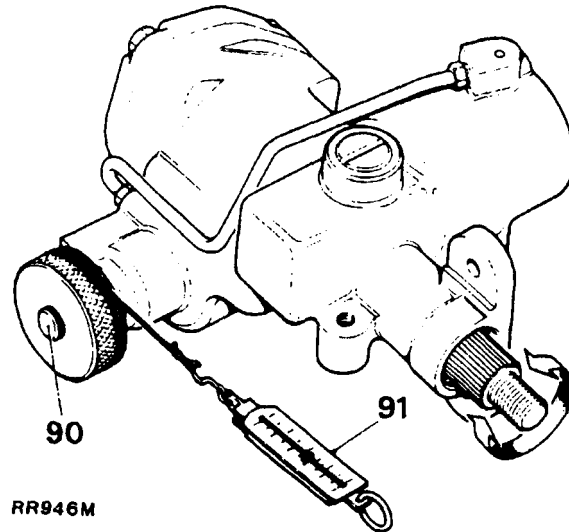

### Adjustments

92. Note where the greatest figures are recorded relative to the steering position. If the greatest figures are not recorded across the **centre of travel** (i.e. steering straight-ahead position), adjust as follows:

If the torque peak occurs **before** the centre position, **add** to the shim washer value; if the torque peak occurs **after** the centre position, **subtract** from the shim washer value.

Shim washers are available as follows:  
0.03mm, 0.07mm, 0.12mm and 0.24mm (0.0015 in, 0.003 in, 0.005 in and 0.010 in).

**NOTE: Adjustment of 0.07mm (0.003 in) to the shim value will move the torque peak area by 1/4 turn approximately on the shaft.**

93. Fit the drop arm to the steering box using a new tab washer. Tighten the nut to the correct torque (see section 06-Torque values) and bend over tab.
94. Refit the steering box to the vehicle.
95. Replenish the system with the correct grade of fluid. Refer to Recommended Lubricants and Power Steering System-bleed.
96. Test the system for leaks, with the engine running, by holding the steering hard on full lock in both directions.

**NOTE: Do not maintain this pressure for more than 30 seconds in any one minute to avoid overheating the fluid and possibly damaging the seals.**

97. Road test the vehicle.

## POWER STEERING SYSTEM

### Bleed

1. Fill the steering fluid reservoir to the appropriate level marking on the dipstick with one of the recommended fluids.
2. Start and run the engine until it attains normal operating temperature.

3. Check and correct the reservoir fluid level.

**NOTE: During the carrying out of items 4, 5 and 6, ensure that the steering reservoir is kept full. Do not increase the engine speed or move the steering wheel.**

4. Run the engine at idle speed, loosen the bleed screw. When fluid seepage **past** the bleed screw is observed, retighten the screw.

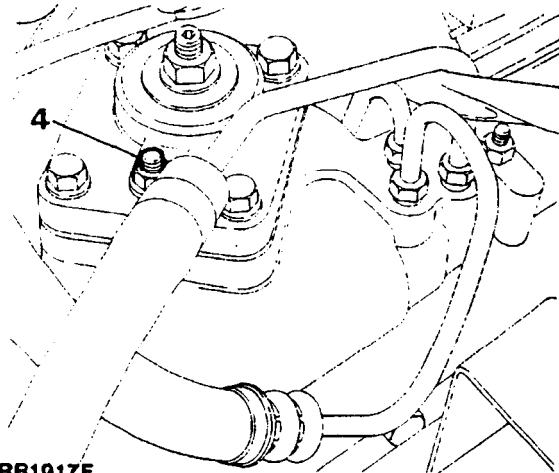

RR1017E

5. Ensure that the fluid level is in alignment with the mark on the dipstick.
6. Wipe off all fluid lost during bleeding.
7. Check all hose connections, pump and steering box for fluid leaks under pressure by holding the steering hard on full lock in both directions.

**CAUTION: Do not maintain this pressure for more than 30 seconds in any one minute, to avoid causing the oil to overheat and possible damage to the seals. The steering should be smooth, lock-to-lock in both directions, that is, no heavy or light spots when changing direction when the vehicle is stationary.**

8. Carry out a short road test. If **necessary**, repeat the complete foregoing procedure.

## POWER STEERING SYSTEM

## Test

If there is a lack of power assistance for the steering the pressure of the hydraulic pump should be checked first before fitting new components to the system. The fault diagnosis chart should also be used to assist in tracing faults in the power steering system.

## SERVICE TOOLS

HY23 -Pressure gauge  
 JD10-2 -Test adaptor  
 LST10-11 -Thread adaptor

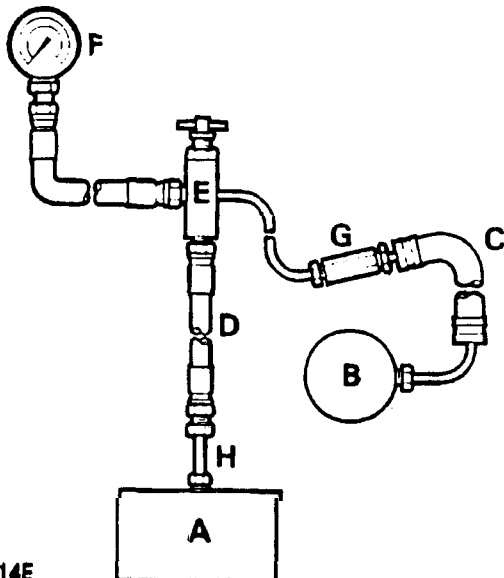

RR1914E

- A. Steering box.
- B. Steering pump.
- C. Existing hose, steering box to pump.
- D. Hose JD10-3A.
- E. Test adaptor JD10-2.
- F. Pressure gauge HY23.
- G. Thread adaptor LST10-11.
- H. Thread adaptor LST10-1.

## Procedure

1. The hydraulic pressure gauge in conjunction with the test adaptor is used for testing the power steering system. This gauge is calibrated to read up to  $140 \text{ kgf/cm}^2$  (2000 p.s.i.) and the normal pressure which may be expected in the power steering system is  $77 \text{ kgf/cm}^2$  (1100 p.s.i.).
2. Under certain fault conditions of the hydraulic pump it is possible to obtain pressures up to  $105 \text{ kgf/cm}^2$  (1500 p.s.i.). Therefore, it is important to realise that the pressure upon the gauge is in direct proportion to the pressure being exerted upon the steering wheel. When testing, apply pressure to the steering wheel very gradually while carefully observing the pressure gauge.
3. Check, and if necessary replenish, the fluid reservoir.
4. Examine the power steering units and connections for leaks. All leaks must be rectified before attempting to test the system.
5. Check the steering pump drive belt for condition and tension, rectify as necessary.
6. Assemble the test equipment and fit to the vehicle, as shown in the diagram.
7. Open the tap in the adaptor.
8. Bleed the system but exercise extreme care when carrying out this operation so as not to overload the pressure gauge.
9. With the system in good condition, the pressures should be as follows:
  - (a) Steering wheel held hard on full lock and engine running at 1,000 rev/min, the pressure should be 70 to  $77 \text{ kgf/cm}^2$  (1000 to 1100 p.s.i.).
  - (b) With the engine idling and the steering wheel held hard on full lock, the pressure should be  $28 \text{ kgf/cm}^2$  (400 p.s.i.) minimum.

These checks should be carried out first on one lock, then on the other.

**CAUTION:** Under no circumstances must the steering wheel be held on full lock for more than 30 seconds in any one minute, otherwise there will be a tendency for the oil to overheat and possible damage to the seals may result.

10. Release the steering wheel and allow the engine to idle. The pressure should be below 7 kgf/cm<sup>2</sup> (100 p.s.i.).
11. If the pressures recorded during the foregoing tests are outside the specified range, or pressure imbalance is recorded, a fault exist in the system. To determine if the fault is in the steering box or the pump, close the adaptor tap for a period not exceeding five seconds.
12. If the gauge fails to register the specified pressure, the pump is at fault and a new unit must be fitted.
13. Repeat the foregoing test after fitting a new pump and bleeding the system. If pump delivery is satisfactory but low pressure or a substantial imbalance exists, the fault must be in the steering box valve and worm assembly.

**ADJUST POWER STEERING BOX**

**NOTE:** The condition of adjustment which must be checked is one of minimum backlash without overtightness when the wheels are in the straight-ahead position.

1. Jack up the front of the vehicle until the wheels are clear of the ground and support the chassis with axle stands.

**WARNING:** It is essential that the wheels are chocked, the parking brake applied, and low range selected with differential lock engaged.

2. Gently rock the steering wheel about the straight-ahead position to obtain the 'feel' of the backlash present. This backlash must not be more than 9.5mm (0.375 in).
3. Continue the rocking action while an assistant slowly tightens the steering box adjuster screw after loosening the locknut until the steering wheel movement is reduced to 9.5mm (0.375 in) maximum.

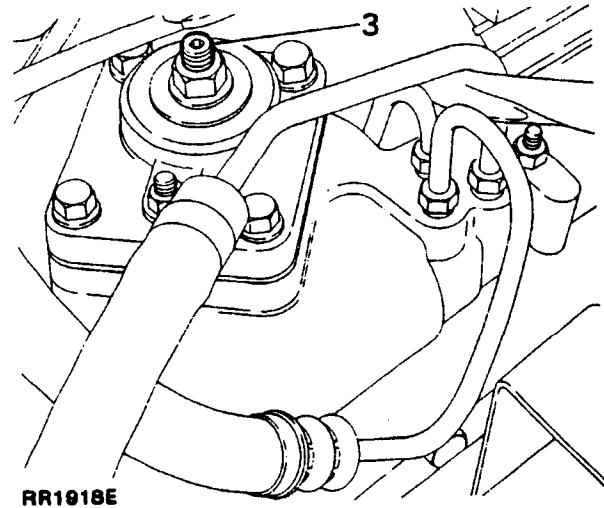

4. Tighten the locknut, then turn the steering wheel from lock to lock and check that no excessive tightness exists at any point.
5. Lower the vehicle to ground level and remove the wheel chocks.
6. Road test the vehicle.

## POWER STEERING FLUID RESERVOIR

## Remove and refit

## Removing

1. Place a drain tray beneath the power steering box.
2. Prop open the hood.
3. Remove the reservoir filler cap.
4. Disconnect the return hose from the steering box. Drain the fluid completely from the reservoir, reconnect the hose.

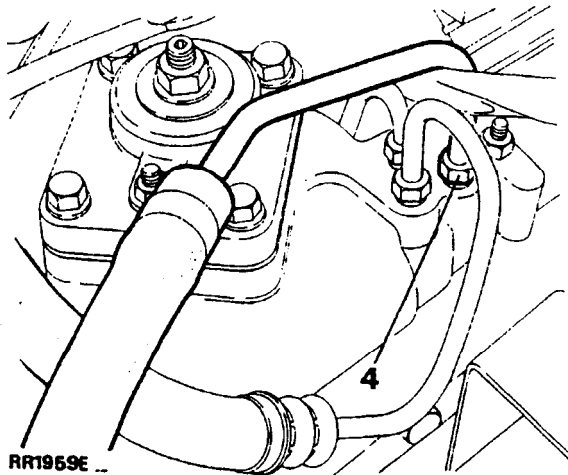

**CAUTION:** Power steering fluid is harmful to paintwork. Should any fluid seep onto body, chassis, or any other components, immediately wipe clean. It is most important that fluid drained from the power steering system is not re-used.

5. Refit the return hose to the steering box.
6. Release the pinch bolt and remove the reservoir from the bracket.
7. Release the hose clamps and remove the flexible hoses, withdraw the reservoir from the engine compartment.

**NOTE:** If the reservoir is not to be refitted immediately, the hoses must be sealed to prevent the ingress of foreign matter.

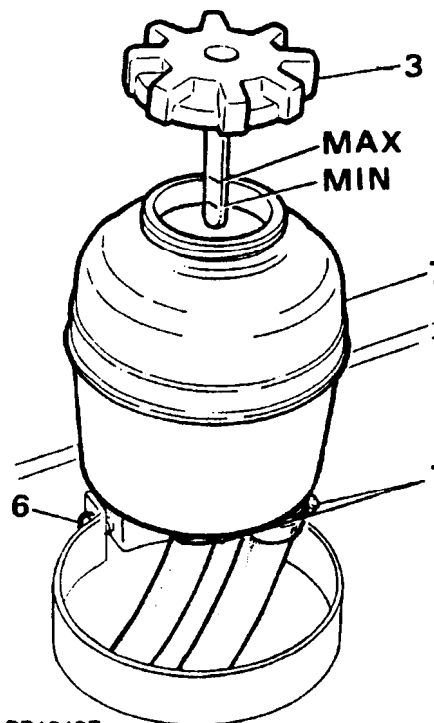

**NOTE:** The reservoir contains an integral filter which is not serviceable, however, in normal use the reservoir unit should last the life of the vehicle. Should the power steering system malfunction and under inspection it is found that the steering fluid has been contaminated by foreign matter a new FLUID RESERVOIR MUST be fitted.

## Refitting

8. Reconnect the flexible hoses to the reservoir. Tighten the hose clamps securely.
9. Refit the reservoir to the bracket and tighten the pinch bolt securely.
10. Fill the reservoir to the prescribed level on the dipstick with one of the recommended fluids (Section 09) and bleed the power steering system. See Power Steering System-bleed.
11. Fit the reservoir filler cap.
12. Close the hood.

POWER STEERING PUMP DRIVE BELT

Adjust

Procedure

1. Prop open the hood and disconnect the battery negative lead.
2. Check, by thumb pressure, the belt tension between the crankshaft and the pump pulley. There should be a free movement of between 4 to 6mm (0.19 to 0.25 in).
3. Loosen the two nuts at the side of the pump to allow the pump to be pivoted.
4. Loosen the bolt securing the pump lower bracket to the slotted adjustment link.
5. Pivot the pump (in the direction of the bold arrow) as necessary and adjust until the correct belt tension is obtained.

**CAUTION:** Do not use the pump casing as a point of leverage when tensioning the power steering drive belt. Damage to the pump casing may be caused leading to fluid leakage.

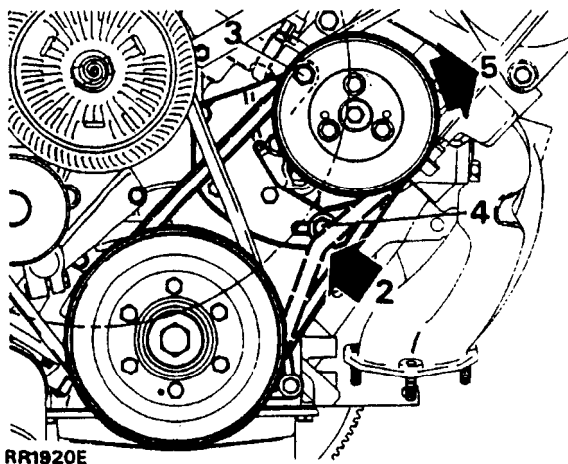

6. Maintaining the tension, tighten the pump adjusting bolt and the top pivot nuts.

**NOTE:** Check the alternator drive belt tension after adjusting the power steering pump belt.

7. Reconnect the battery negative lead and close the hood.

**NOTE:** Check adjustment after running engine at fast idle speed for 3 to 5 minutes if a new belt has been fitted.

POWER STEERING PUMP DRIVE BELT

Remove and refit

Removing or preparing for the fitting of a new belt.

1. Prop open the hood and disconnect the battery negative lead.
2. Loosen the idler pulley bolt and remove the fan belt.
3. Loosen the alternator mountings and remove the drive belt.
4. Loosen the power steering pump mountings.
5. Pivot the pump and remove the drive belt.

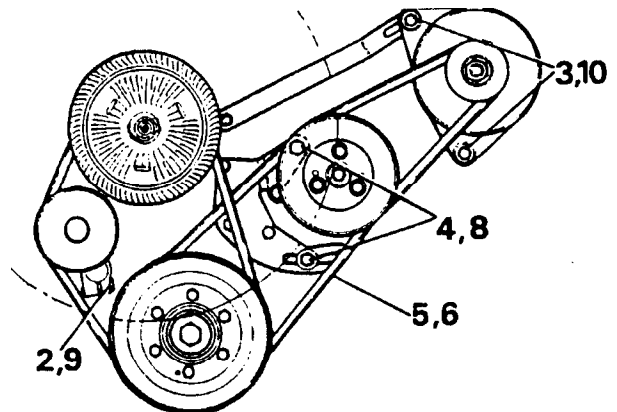

RR1921E

Refitting

6. Locate the driving belt over the crankshaft and pump pulleys.
7. Adjust the position of the pump to give a driving belt tension of 4 to 6mm (0.19 to 0.25 in) movement when checked by thumb pressure midway between the crankshaft and pump pulleys.

**CAUTION:** Do not use the pump casing as a point of leverage when-tensioning the power steering drive belt. Damage to the pump casing may be caused leading to fluid leakage.

8. Maintaining the tension, tighten the pump adjusting bolt and the top pivot nut.
9. Refit the fan belt and adjust the tension to give 4 to 6mm (0.19 to 0.25 in) movement when checked by thumb pressure midway between the crankshaft and water pump pulleys.

Continued

10. Refit the alternator drive belt and adjust to give 4 to 6mm (0.19 to 0.25 in) movement when checked midway between the power steering pump and alternator pulleys.
11. Reconnect the battery negative lead and close the hood.

**NOTE:** Check adjustment after running engine at fast idle speed for 3 to 5 minutes if a new belt has been fitted.

#### STEERING PUMP

**NOTE:** The power steering pump is not a serviceable item. In the event of failure or damage a new pump must be fitted.

#### Remove and refit

##### Removing

1. Disconnect the battery negative lead.
2. Loosen the alternator pivot bolts and adjustment link bolts, pivot the alternator inwards and remove the drive belt.
3. Loosen the water pump drive belt idler pulley and remove the drive belt.
4. Remove the left hand bank spark plug leads and detach the distributor cap, place the leads and cap to one side.
5. Disconnect the electrical plug from the distributor amplifier unit.
6. Loosen the two nuts securing the power steering pump pivot bracket.
7. Release the three bolts securing the pulley to the steering pump, do not remove them at this stage.
8. Release the bottom adjustment bolt below the steering pump and pivot the pump inwards towards the water pump to enable the drive belt to be removed.

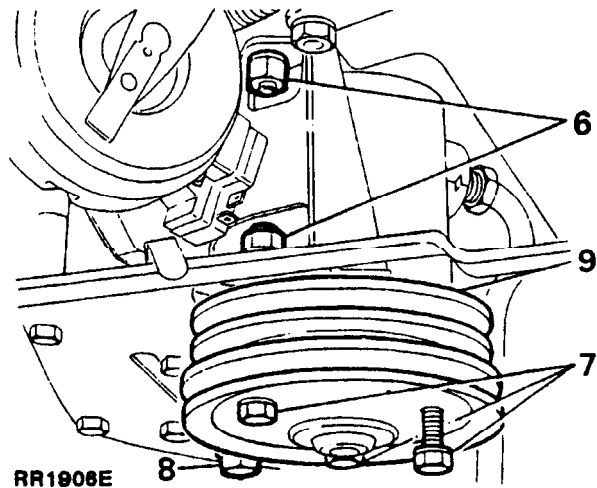

RR1906E

9. Remove the three bolts with plain washers retaining the pulley to the pump and withdraw the pulley.

**NOTE:** Place a drain tray underneath the vehicle to catch any power steering fluid which will seep from the pump when the fluid pipe is disconnected.

**CAUTION:** Power steering fluid is harmful to paintwork. Should any fluid seep onto the body, chassis, or any other components immediately wipe clean. It is most important that fluid drained from the power steering system is not re-used.

10. Disconnect the fluid pipe from the side of the pump, plug the pipe and pump openings to prevent ingress of dirt.

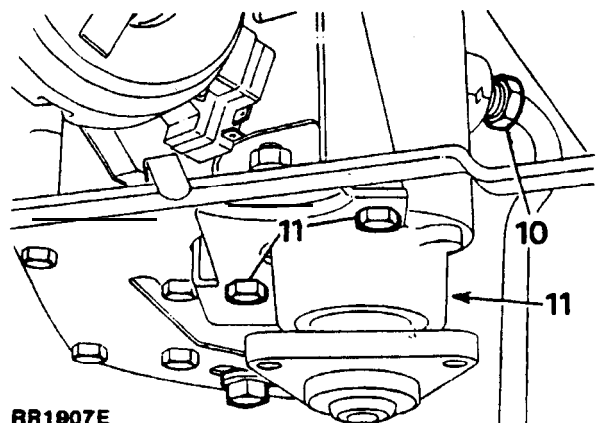

RR1907E



11. Remove the three bolts securing the pump to the pivot bracket, maneuver the pump out of the bracket and withdraw it from the engine compartment as far as the remaining connected fluid hose will permit.
12. Release the clamp securing the hose to the pump, remove the hose and plug both openings to prevent ingress of dirt.

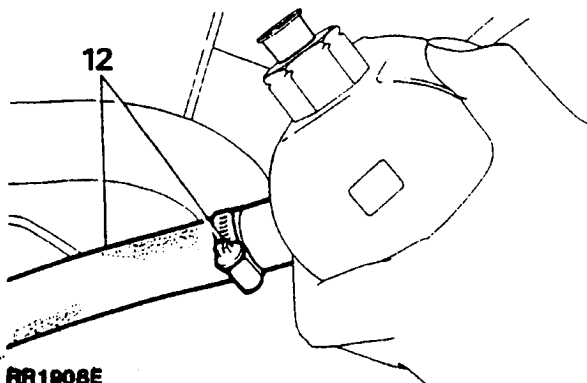

RR1808E

#### Refitting

13. Remove the plug from the fluid hose and secure the hose to a NEW pump. Tighten the hose clamp securely.
14. Maneuver the pump into the pivot bracket and secure in position with the three retaining bolts. Tighten the bolts to the specified torque (see section 06-Torque values).
15. Remove the plugs from the fluid pipe and steering pump openings and fit the pipe. Tighten the pipe securely.
16. Fit the pulley to the steering pump drive flange, coat the three bolts with Loctite and fit to the steering pump, do not-fully tighten the bolts at this stage.
17. Refit the crankshaft to steering pump drive belt, pivot the steering pump outwards to tension the belt, tighten the pivot bolts securely. Check that the belt deflects approximately 4 to 6 mm (0.19 to 0.25in) when checked by thumb pressure midway between the crankshaft and pump pulleys.
18. Tighten the three steering pump pulley retaining bolts to the specified torque (see section 06-Torque values).
19. Reverse the remaining removal instructions.
20. Bleed the power steering system.
21. Test the power steering system for leaks with the engine running, holding the steering on full lock in both directions.
22. Close the hood.
23. Road test the vehicle.

**CAUTION:** Do not maintain this pressure for more than 30 seconds in any one minute, to avoid causing the oil to overheat and possible damage to the seals.

**CAUTION:** Care should be taken to ensure that the high pressure fluid pipe is well clear of both the drive belt and the top of the power steering box.

**POWER STEERING**

**FAULT DIAGNOSIS**

SYMPTOM	CAUSE	TEST ACTION	CURE
<p><b>INSUFFICIENT POWER ASSISTANCE WHEN PARKING</b></p>	<p>(1) Lack of fluid</p> <p>(2) Driving belt</p> <p>(3) Defective hydraulic pump</p>	<p>Check hydraulic fluid tank level</p> <p>Check belt tension</p> <p>(a) Fit pressure gauge between high pressure hose and steering pump with steering held hard on full lock, see Note 1 and 'Power Steering System Test'</p> <p>(b) Release steering wheel and allow engine to idle. See 'Power Steering System Test'</p>	<p>If low, fill and bleed the system</p> <p>Adjust the driving belt</p> <p>If pressure is outside limits (high or low) after checking items 1 and 2, see Note 2</p> <p>If pressure is greater, check box for freedom and self-centering action</p>
<p><b>POOR HANDLING WHEN VEHICLE IS IN MOTION</b></p>	<p>Lack of castor action (wheels will not return to centre)</p>	<p>This is caused by over-tightening the rocker shaft backlash adjusting screw on top of the steering box</p>	<p>It is most important that this screw is correctly adjusted. See instructions governing adjustment</p>
<p><b>HYDRAULIC FLUID LEAKS</b></p>	<p>Damaged pipework, loose connecting unions etc.</p>	<p>Check by visual inspection; leaks from the high pressure lines are best found while holding the steering on full lock with engine running at fast idle speed (See Note 1)</p> <p>Check 'O' rings on pipework</p>	<p>Tighten or renew as necessary</p> <p>Renew as necessary</p>

Continued

SYMPTOM	CAUSE	TEST ACTION	CURE
EXCESSIVE NOISE	(1) If the high pressure hose is allowed to come into contact with the body shell, or any component not insulated by the body mounting, noise will be transmitted to the car interior	Check the loose runs of the hoses	Alter hose route or insulate as necessary
	(2) Noise from hydraulic pump	Check oil level and bleed system	If no cure, change hydraulic pump
<p><b>Note 1.</b> Never hold the steering wheel on full lock for more than 30 seconds in any one minute, to avoid causing the oil to overheat and possible damage to the seals.</p> <p><b>Note 2.</b> High pressure- In general it may be assumed that excessive pressure is due to a fault in the hydraulic pump.                      Low pressure- Insufficient pressure may be caused by one of the following:</p> <ol style="list-style-type: none"> <li>1. Low fluid level in reservoir ) Most usual cause of</li> <li>2. Pump belt slip ) insufficient pressure</li> <li>3. Leaks in the power steering system</li> <li>4. Hydraulic pump not delivering correct pressure</li> <li>5. Fault in steering box valve and worm assembly</li> <li>6. Leak at piston sealing in steering box</li> <li>7. Worn components in either steering box or hydraulic pump</li> </ol>			

**Steering pump**

Make/type ..... Hobourn-Eaton series 200  
 Operating pressure • straight ahead position • at idle ..... 7 kgf/cm<sup>2</sup> (100 p.s.i.) maximum  
 Full lock (left or right) at idle ..... 28 kgf/cm<sup>2</sup> (400 p.s.i.) minimum  
 Full lock (left or right) 1000 rev/min ..... 70-77 kgf/cm<sup>2</sup> (1000-1100 p.s.i.)

## COUPLING SHAFT AND UNIVERSAL JOINTS

## Remove and refit

**CAUTION:** PRIOR TO REMOVING ANY OF THE COMPONENTS INCORPORATED IN THE STEERING LINKAGE, IT IS IMPERATIVE THAT THE ROAD WHEELS ARE IN A STRAIGHT AHEAD POSITION AND THAT THE STEERING WHEEL IS THEN REMOVED TO PREVENT THE CRUISE CONTROL SPIRAL CASSETTE BEING WOUND UP OR DAMAGED IF THE STEERING LINKAGE IS INADVERTENTLY MOVED OR ROTATED.

AFTER REFITTING STEERING LINKAGE COMPONENTS, THE ROAD WHEELS MUST BE RE-POSITIONED STRAIGHT AHEAD BEFORE FITTING THE STEERING WHEEL, DO NOT RECONNECT THE MULTI-PLUG TO THE CASSETTE OR FIT THE TRIM PAD AT THIS STAGE. IF, AFTER THE VEHICLE HAS BEEN DRIVEN, IT IS FOUND THAT THE STEERING WHEEL REQUIRES RE-POSITIONING, REMOVE THE WHEEL. RE-ALIGN THE DRIVE PEGS ON THE CRUISE CONTROL CASSETTE BY SLIGHTLY ROTATING THE UPPER PART OF THE CASSETTE IN THE APPROPRIATE DIRECTION UNTIL THE PEGS LIE HORIZONTAL TO THE STEERING COLUMN.

FIT THE STEERING WHEEL ENSURING THAT THE DRIVE PEGS LOCATE IN THEIR RESPECTIVE HOLES ON THE REAR OF THE STEERING WHEEL.

AFTER FINAL ALIGNMENT RE-CONNECT THE MULTI-PLUG TO THE CASSETTE, TIGHTEN THE STEERING WHEEL SECURING NUT AND FIT THE TRIM PAD.

## Removing

1. Ensure the road wheels are in the straight ahead position.

**NOTE:** To gain access to the coupling shaft it is necessary to remove the air flow sensor and air filter canister.

2. Remove one pinch bolt from the top universal joint to the steering column.
3. Remove two pinch bolts from the lower universal joint.
4. Maneuver the coupling shaft top universal joint up the steering column splines to release the lower joint from the steering box splines. Withdraw the shaft from the steering column splines.
5. Withdraw the lower universal joint from the coupling shaft.

**NOTE:** Do not dismantle the upper coupling joint. The steering shaft, rubber coupling and top universal joint is only available as an assembly.

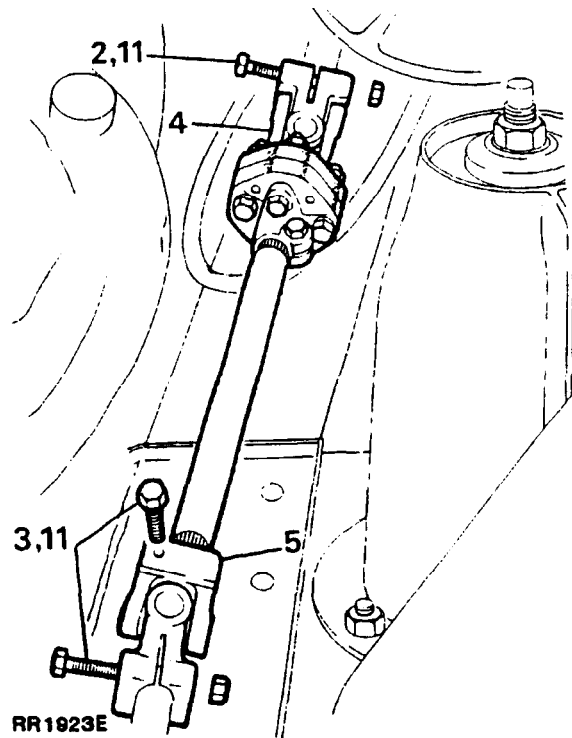

6. Inspect both universal joints for wear and excessive play, fit new joints if necessary.
7. Inspect the rubber coupling for condition - rubber deterioration, fit a new rubber coupling assembly if necessary.

## Refitting

**NOTE:** When refitting the universal joints to their respective components ensure that the pinch bolt holes line up with their respective grooves.

8. Position the lower universal joint on the shaft.
9. Position the shaft assembly toward the end of the steering column, maneuver the assembly up the steering column splines until it is possible to locate the lower universal joint onto the steering box splines.
10. Locate the bolt holes in the universal joints with their respective grooves in the steering column, coupling shaft and steering box splines.
11. Fit the pinch bolts, and tighten to the correct torque (see section 06-Torque values).

**STEERING WHEEL**

Remove and refit

**CAUTION: PRIOR TO REMOVING ANY OF THE COMPONENTS INCORPORATED IN THE STEERING LINKAGE, IT IS IMPERATIVE THAT THE ROAD WHEELS ARE IN A STRAIGHT AHEAD POSITION AND THAT THE STEERING WHEEL IS THEN REMOVED TO PREVENT THE CRUISE CONTROL SPIRAL CASSETTE BEING WOUND UP OR DAMAGED IF THE STEERING LINKAGE IS INADVERTENTLY MOVED OR ROTATED.**

**AFTER REFITTING STEERING LINKAGE COMPONENTS, THE ROAD WHEELS MUST BE RE-POSITIONED STRAIGHT AHEAD BEFORE FITTING THE STEERING WHEEL! DO NOT RECONNECT THE MULTI-PLUG TO THE CASSEITE OR FIT THE TRIM PAD AT THIS STAGE. IF, AFTER THE VEHICLE HAS BEEN DRIVEN, IT IS FOUND THAT THE STEERING WHEEL REQUIRES RE-POSITIONING, REMOVE THE WHEEL. RE-ALIGN THE DRIVE PEGS ON THE CRUISE CONTROL CASSETTE BY SLIGHTLY ROTATING THE UPPER PART OF THE CASSETTE IN THE APPROPRIATE DIRECTION UNTIL THE PEGS LIE HORIZONTAL TO THE STEERING COLUMN.**

**FIT THE STEERING WHEEL ENSURING THAT THE DRIVE PEGS LOCATE IN THEIR RESPECTIVE HOLES ON THE REAR OF THE STEERING WHEEL.**

**AFTER FINAL ALIGNMENT RE-CONNECT THE MULTI-PLUG TO THE CASSEITE, TIGHTEN THE STEERING WHEEL SECURING NUT AND FIT THE TRIM PAD.**

Removing

Service Tools:

18G 1014 Steering wheel remover

18G 1014-2 Adaptor pins

**NOTE:** The steering column is of a 'safety' type and incorporates shear pins. Therefore do not impart shock loads to the steering column during removing and refitting the steering wheel or at any time.

1. Disconnect the battery negative lead.
2. Ensure the road wheels are in the straight ahead position to enable the steering wheel to be fitted in its correct location on re-assembly.
3. Carefully ease the centre trim pad off the steering wheel.

4. Disconnect the cruise control electrical multi-plug located in the small opening below the centre retaining nut.
5. While holding the steering wheel remove the retaining nut and serrated washer.
6. Extract the steering wheel using service tool 18G 1014. Ensure the extractor pins are inserted in the threads up to shoulder of the pins.

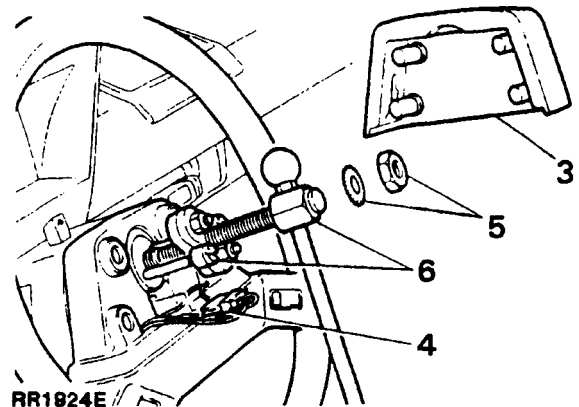

RR1924E

**CAUTION: IT IS IMPERATIVE THAT THE UPPER PART OF THE CRUISE CONTROL CASSEITE IS NOT ROTATED AFTER THE STEERING WHEEL IS REMOVED. TO PREVENT ROTATION SECURE THE UPPER AND LOWER PART OF THE CASSEITE IN POSITION WITH ADHESIVE TAPE.**

Refitting

7. Ensure the road wheels are in the straight ahead position.
8. Place the steering wheel on the column splines and remove the previously applied adhesive tape to the spiral cassette.
9. Ensure the two drive pegs on the upper part of the cassette align with their respective location holes on the underside of the steering wheel, ease the wheel onto the pegs.

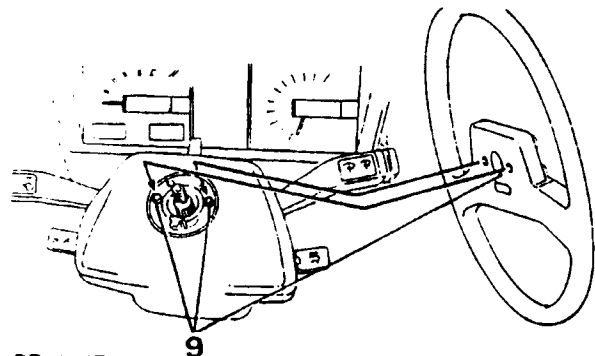

RR1925E

Continued

**CAUTION:** Do not apply shock loads to the steering wheel.

10. Fit the nut and washer and tighten to the specified torque (see section 06-Torque values).
11. Reconnect the cruise control multi-plug and refit the steering wheel centre cover.
12. Reconnect the battery.

## STEERING COLUMN

**NOTE:** The steering column assembly is not a serviceable component.

Remove and refit

Service tool:

- 18G1014-Extractor for steering wheel.
- 18G1014-2 Adaptor pins.

**CAUTION:** The steering column is of a 'safety' type and incorporates shear pins. Therefore do not impart shock loads to the steering column at any time.

**CAUTION:** PRIOR TO REMOVING ANY OF THE COMPONENTS INCORPORATED IN THE STEERING LINKAGE, IT IS IMPERATIVE THAT THE ROAD WHEELS ARE IN A STRAIGHT AHEAD POSITION AND THAT THE STEERING WHEEL IS THEN REMOVED TO PREVENT THE CRUISE CONTROL SPIRAL CASSETTE BEING WOUND UP OR DAMAGED IF THE STEERING LINKAGE IS INADVERTENTLY MOVED OR ROTATED.

AFTER REFITTING STEERING LINKAGE COMPONENTS, THE ROAD WHEELS MUST BE RE-POSITIONED STRAIGHT AHEAD BEFORE FITTING THE STEERING WHEEL, DO NOT RECONNECT THE MULTI-PLUG TO THE CASSETTE OR FIT THE TRIM PAD AT THIS STAGE. IF, AFTER THE VEHICLE HAS BEEN DRIVEN, IT IS FOUND THAT THE STEERING WHEEL REQUIRES RE-POSITIONING, REMOVE THE WHEEL. RE-ALIGN THE DRIVE PEGS ON THE CRUISE CONTROL CASSETTE BY SLIGHTLY ROTATING THE UPPER PART OF THE CASSETTE IN THE APPROPRIATE DIRECTION UNTIL THE PEGS LIE HORIZONTAL TO THE STEERING COLUMN.

FIT THE STEERING WHEEL ENSURING THAT THE DRIVE PEGS LOCATE IN THEIR RESPECTIVE HOLES ON THE REAR OF THE STEERING WHEEL.

AFTER FINAL ALIGNMENT RECONNECT THE MULTI-PLUG TO THE CASSETTE, TIGHTEN THE STEERING WHEEL SECURING NUT AND FIT THE TRIM PAD.

Removing

1. Remove the steering wheel using extractor 18G1014 and adaptor pins.

**CAUTION:** IT IS IMPERATIVE THAT THE UPPER PART OF THE CRUISE CONTROL CASSETTE IS NOT ROTATED AFTER THE STEERING WHEEL IS REMOVED. TO PREVENT ROTATION SECURE THE UPPER AND LOWER PART OF THE CASSETTE IN POSITION WITH ADHESIVE TAPE.

2. Remove the lower dash panel and unclip the lower trim pad from the driver's side.
3. Disconnect the electrical multi-plugs from the steering column switches and release the electrical wiring from the retaining clip located half way down the steering column.
4. Remove the steering column shroud fixings and maneuver the shroud off the column switches.
5. Remove the top pinch bolt, universal joint to steering column.
6. Remove the fixings, steering column to floor board.
7. Remove the fixings, steering column to dash bracket.
8. Withdraw the steering column assembly.

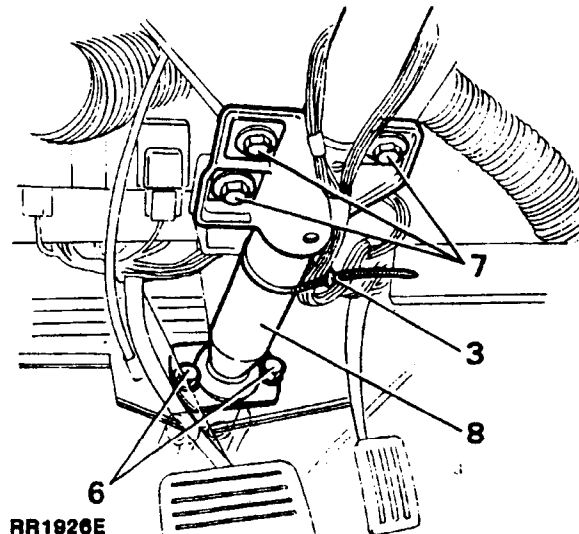

**Refitting**

9. Position the sealing gasket on the end of the column assembly.
10. Feed the steering shaft through the floor board and engage the drive splines at the coupling shaft.
11. Fit the column upper fixings, do not fully tighten at this stage.
12. Fit the column lower fixings, do not fully tighten at this stage.
13. Tighten the lower fixings to the specified torque (see section 06-Torque values).
14. Fit universal joint pinch bolt, and tighten to the correct torque (see section 06-Torque values).
15. Tighten the column upper fixings to the specified torque (see section 06-Torque values).
16. Reverse 1 to 4.

**STEERING COLUMN LOCK ASSEMBLY**

**Remove and refit**

**Service tool:**  
**18G1014** Extractor for steering wheel.  
**18G1014-2** Adaptor pins.

For ignition/starter switch-remove and refit as described in Electrical Section 86.

**CAUTION: PRIOR TO REMOVING ANY OF THE COMPONENTS INCORPORATED IN THE STEERING LINKAGE, IT IS IMPERATIVE THAT THE ROAD WHEELS ARE IN A STRAIGHT AHEAD POSITION AND THAT THE STEERING WHEEL IS THEN REMOVED TO PREVENT THE CRUISE CONTROL SPIRAL CASSEITE BEING WOUND UP OR DAMAGED IF THE STEERING LINKAGE IS INADVERTENTLY MOVED OR ROTATED.**

**AFTER REFITTING STEERING LINKAGE COMPONENTS, THE ROAD WHEELS MUST BE RE-POSITIONED STRAIGHT AHEAD BEFORE FITTING THE STEERING WHEEL, DO NOT RECONNECT THE MULTI-PLUG TO THE CASSEITE OR FIT THE TRIM PAD AT THIS STAGE. IF, AFTER THE VEHICLE HAS BEEN DRIVEN, IT IS FOUND THAT THE STEERING WHEEL REQUIRES RE-POSITIONING, REMOVE THE WHEEL. RE-ALIGN THE DRIVE PEGS ON THE CRUISE CONTROL CASSEITE BY SLIGHTLY ROTATING THE UPPER PART OF THE CASSEITE IN THE APPROPRIATE DIRECTION UNTIL THE PEGS LIE HORIZONTAL TO THE STEERING COLUMN.**

**FIT THE STEERING WHEEL ENSURING THAT THE DRIVE PEGS LOCATE IN THEIR RESPECTIVE HOLES ON THE REAR OF THE STEERING WHEEL.**

**AFTER FINAL ALIGNMENT RE-CONNECT THE MULTI-PLUG TO THE CASSEITE, TIGHTEN THE STEERING WHEEL SECURING NUT AND FIT THE TRIM PAD.**

**Removing**

1. Disconnect the battery negative lead.
2. Carefully detach the steering wheel centre cover and using service tool 18G1014 and adaptor pins remove the steering wheel.

**CAUTION: IT IS IMPERATIVE THAT THE UPPER PART OF THE CRUISE CONTROL CASSEITE IS NOT ROTATED AFTER THE STEERING WHEEL IS REMOVED. TO PREVENT ROTATION SECURE THE UPPER AND LOWER PART OF THE CASSEITE IN POSITION WITH ADHESIVE TAPE.**

3. Release the fixings securing the shroud to the steering column and withdraw the shroud.
4. Release the column switches from the switch housing to gain access to the column lock fixings.
5. Using a sharp punch and a hammer, lightly tap the head of the shear pins in a counter-clockwise direction to release them from the column lock housing.

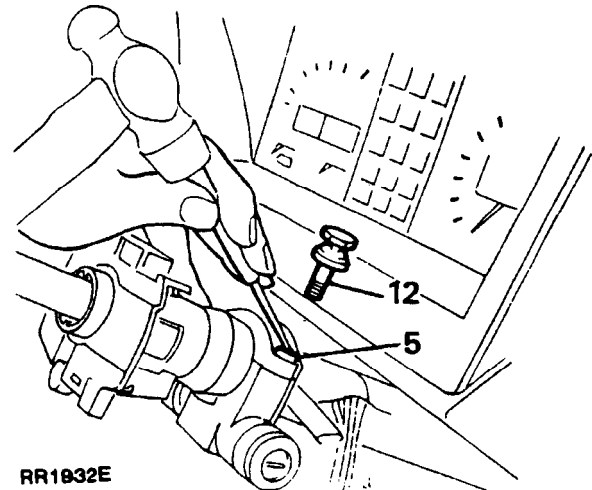

6. Remove the sheared bolts.
7. Detach the upper cap.
8. Withdraw the lower column lock assembly.

**Continued**

**Refitting**

9. Position the steering lock upper cap on the outer column, locating the spigot in the hole provided.
10. Place the lower lock assembly into the column.
11. Fit the shear bolts to retain the cap and lock.
12. Tighten the bolts sufficient to shear off the heads.
13. Reverse 1 to 4.

**DROP ARM**

**Remove and refit**

**Service tools:**  
**MS252A** Drop arm extractor

**Removing**

1. Place the vehicle on a suitable hydraulic hoist, alternatively raise the front of the vehicle using a hydraulic floor jack and install axle stands under the front axle, remove the floor jack.
2. Disconnect the drag link from the drop arm ball joint, using a suitable extractor.

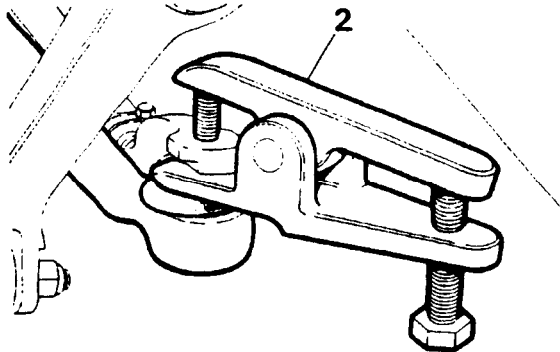

**RR1939E**

3. Remove the drop arm from the steering box rocker shaft, using extractor **MS252A**.

**NOTE:** The drop arm ball joint is integral with the drop arm.

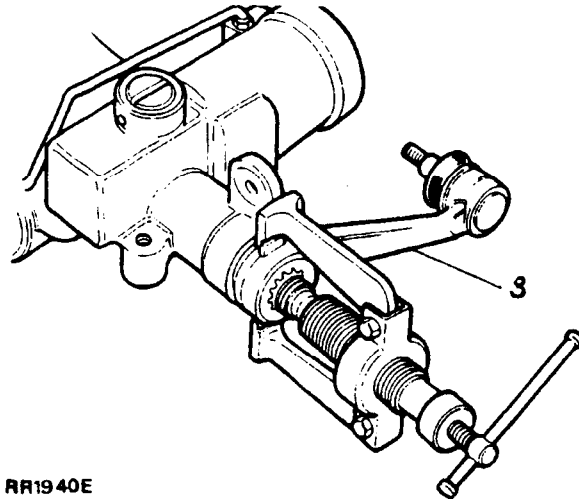

**RR1940E**

**Refitting**

4. Set the steering box in the midway lock-to-lock position.
5. Fit the drop arm in position, aligning the master splines.
6. Fit the drop arm fixings and tighten to the correct torque (see section 06-Torque values).
7. Fit the drag link and tighten to the correct torque (see section 06-Torque values).

**DROP ARM BALL JOINT**

**Overhaul**

The drop arm ball joint can be overhauled with a repair kit available which consists of the the following items:

<b>Ball pin</b>	<b>Ball lower socket</b>
<b>Retainer</b>	<b>Spring</b>
<b>Spring rings</b>	<b>'O' ring</b>
<b>Dust cover</b>	<b>Cover-plate</b>
<b>Ball top socket</b>	<b>Circlip</b>

**Dismantle**

- 1 Remove the drop arm from the vehicle and clean the exterior.
- 2 Remove the spring rings and prise off the dust cover.
- 3 In the Interests of safety, position the ball joint under a press to relieve the spring tension and support the housing both sides of the ball pin, as illustrated. Apply pressure to the cover plate and remove the circlip and slowly release the pressure.

**WARNING:** Personal injury could result if the circlip is removed without pressure being applied and maintained to the cover plate.

Continued



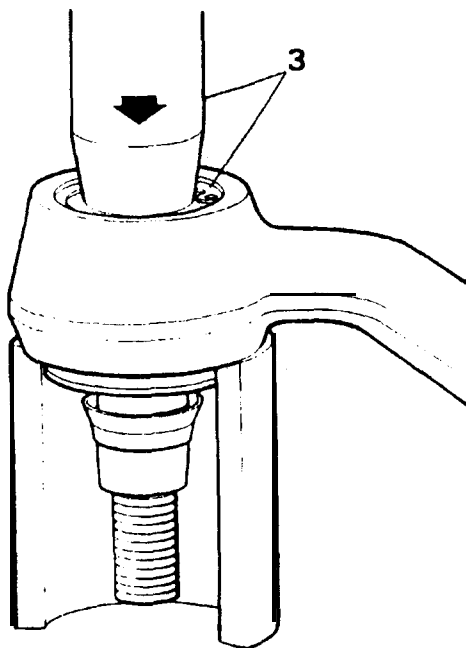

ST1382M

4. Remove the spring, top socket and 'O' ring.
5. Since the ball pin cannot be removed with the retainer in position, tap the threaded end of the ball pin to release the retainer and to remove the pin from the housing.

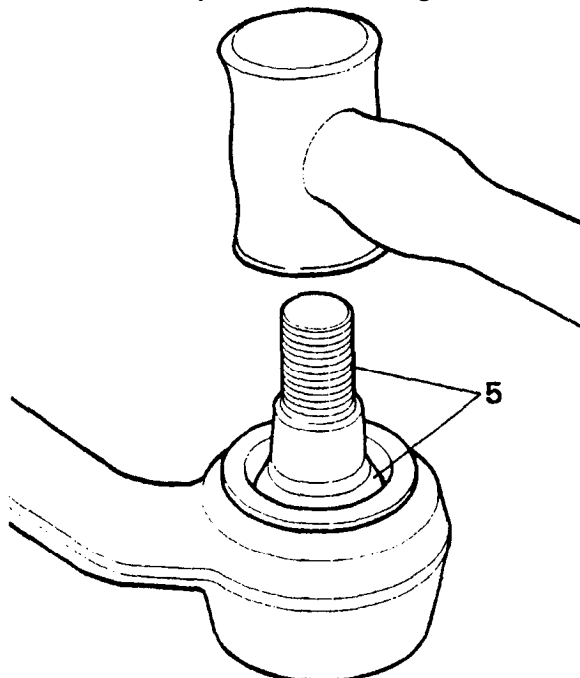

ST1383M

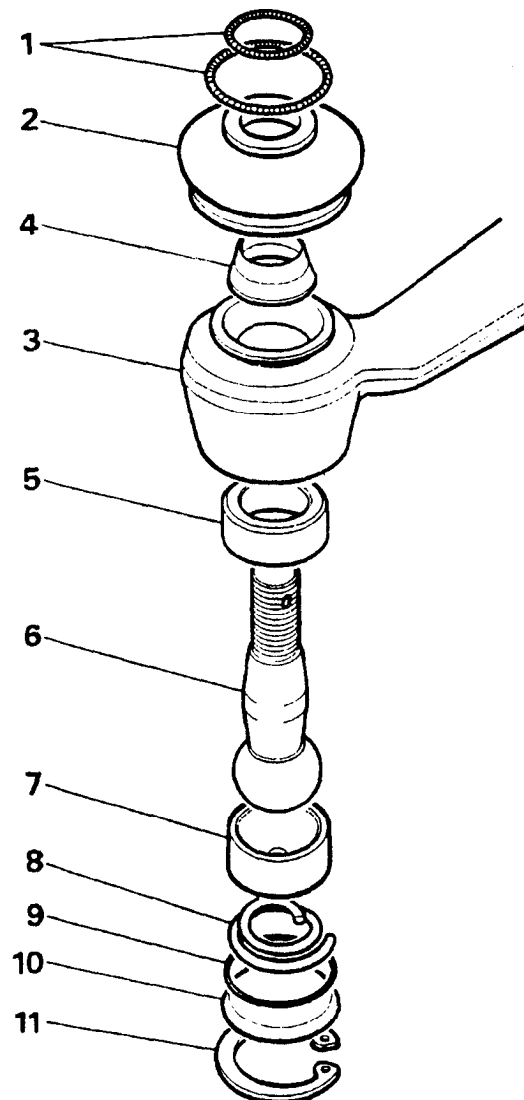

ST1381M

KEY TO BALL JOINT

1. Spring rings
2. Dust cover
3. Bill housing
4. Retainer
5. Bottom socket
6. Ball pin
7. Top socket
8. Spring
9. 'O' ring
10. Cover-plate
11. Circlip

6. Using a sharp-edged punch or chisel, drive the ball lower socket from the housing.
7. Clean the housing and remove any burrs.



ST1384M

## Assemble

8. Press in the lower socket squarely up to the shoulder.
9. Dip the ball in **Duckhams LB10** grease, or equivalent and fit to the housing and pack with grease.
10. Fit the top socket.
11. Fit the spring, small diameter towards the ball.
12. Fit the 'O' ring and using the same method as for removing the circlip, compress the cover plate and secure with the circlip. Ensure that the circlip is fully seated in the machined groove
13. Press the retainer onto the ball pin so that the top edge is level with the edge of the taper.
14. Fit the dust cover and retain with the two spring rings.
15. Fit the drop arm to the steering box using a new lock washer. Tighten the retaining nut to the correct torque (see section 06-Torque values) and bend over the lock washer.
16. Assemble the ball pin to the drag link, see instructions for fitting drag link and track rod, tighten the castle nut to the correct torque (see section 06-Torque values) and secure with a new cotter pin.

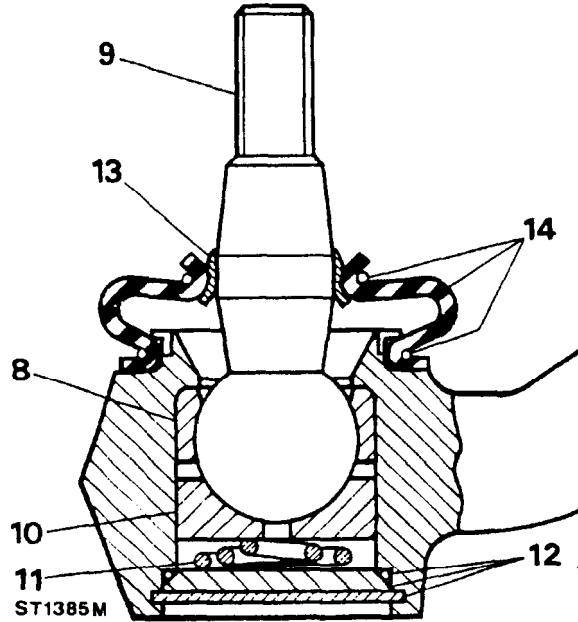

TRACK ROD AND LINKAGE

Remove and refit

TRACK ROD

Removing

1. Place the vehicle on a suitable hydraulic hoist, alternatively raise the front of the vehicle using a hydraulic floor jack and install axle stands under the front axle, remove the floor jack.
2. Disconnect the steering damper at the track rod.
3. Disconnect the track rod at the ball joints, using a suitable extractor.
4. Withdraw the complete track rod.

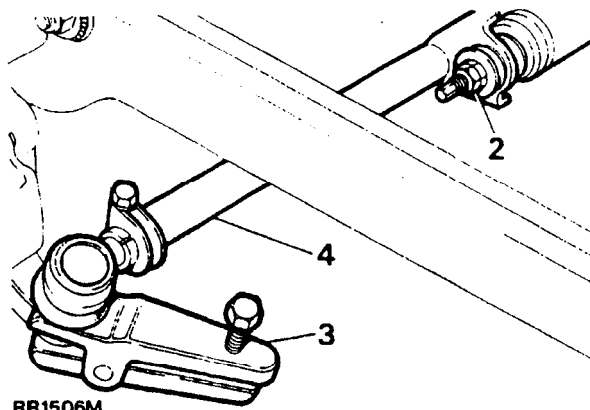

RR1506M

LINKAGE

Removing

5. Loosen the clamp bolts.
6. Unscrew the ball joints.
7. Unscrew the track rod adjuster, left hand thread.

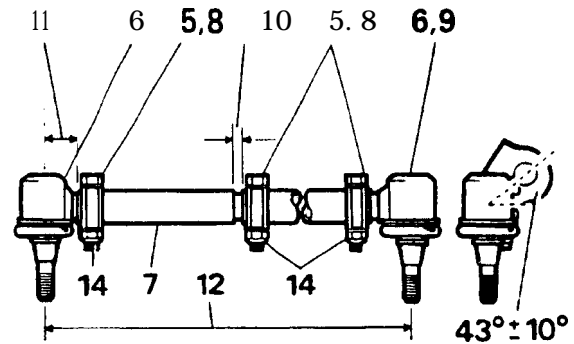

RR1507M

Refitting

8. Fit the replacement parts. Do not tighten the clamp pinch bolts at this stage.
9. Screw in a ball joint to the full extent of the threads.
10. Set the adjuster dimensionally to the track rod as illustrated, to 8.9mm (0.350 in).
11. Set the adjuster end ball joint dimensionally, as illustrated to 28.57mm (1.125 in).
12. The track rod effective length of 1230.0mm (48.4 in) is subject to adjustment during the subsequent wheel alignment check.

TRACK ROD

Refitting

13. Fit the track rod and tighten the ball joint nuts to the correct torque (see section 06-Torque values).
14. Check the front wheel alignment.
15. Reverse 1 and 2.

CAUTION: A new track rod must be fitted if the existing track rod is damaged or bent. No attempt should be made to repair or straighten it.

## STEERING DAMPER

## Remove and refit

## Removing

1. Place the vehicle on a suitable hydraulic hoist, alternatively raise the front of the vehicle using a hydraulic floor jack and place axle stands under the front axle, remove the floor jack.
2. Remove the fixings at the differential case bracket.
3. Remove the fixings at the track rod bracket.
4. Withdraw the steering damper.

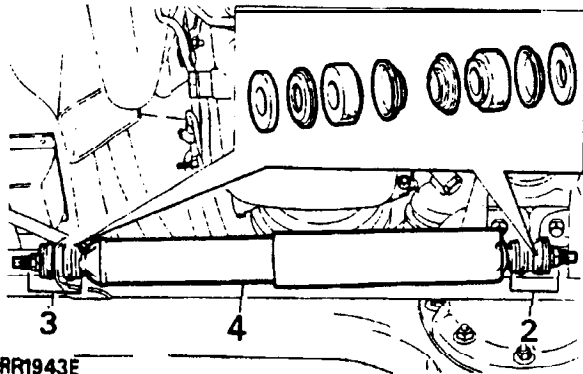

RR1943E

## Refitting

5. Reverse 1 to 4.

## DRAG LINK AND DRAG LINK ENDS

## Remove and refit

## Removing

1. Place the vehicle on a suitable hydraulic hoist, alternatively raise the front of the vehicle using a hydraulic floor jack and place axle stands under the front axle-remove the floor jack.
2. Remove the right hand front road wheel.
3. Disconnect the drag link ball joint at the swivel housing arm, using a suitable extractor.
4. Disconnect the drag link end at the drop arm ball joint, using a suitable extractor.
5. Withdraw the drag link.

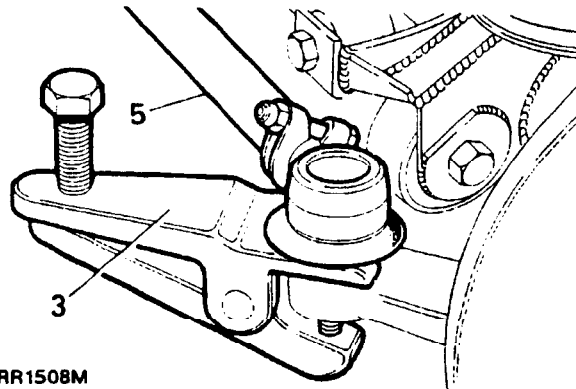

RR1508M

## DRAG LINK ENDS

## Removing

6. Loosen the clamp bolts.
7. Unscrew the ball joint.
8. Unscrew the offset end.

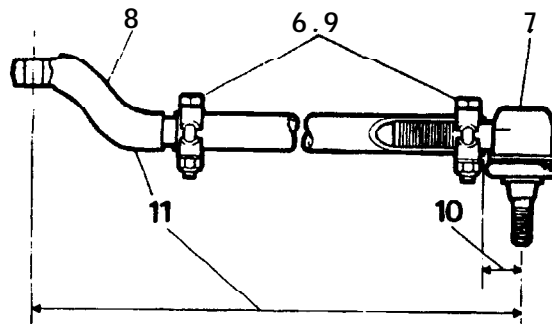

RR 1509M

## Refitting

9. Fit the replacement ends. Do not tighten the clamp bolts at this stage.
10. Set the ball joint dimensionally to the drag link, as illustrated, to 28.57mm (1.125 in).
11. Adjust the offset end to obtain the nominal overall length of 919.0mm (36.2 in). The final length is adjusted during refitting.

DRAG LINK

Refitting

12. Fit the drag link. Tighten the ball-joint nuts to the correct torque (see section 06-Torque values).
- 13 Check, and if necessary, set the steering lock stops.
14. Turn the steering and ensure that full travel is obtained between the lock stops. Adjust the drag link length to suit.
15. Using a mallet, tap the ball joints in the direction indicated so that both pins are in the same angular plane.
16. Tighten the clamp bolts to the correct torque (see section 06-Torque values).

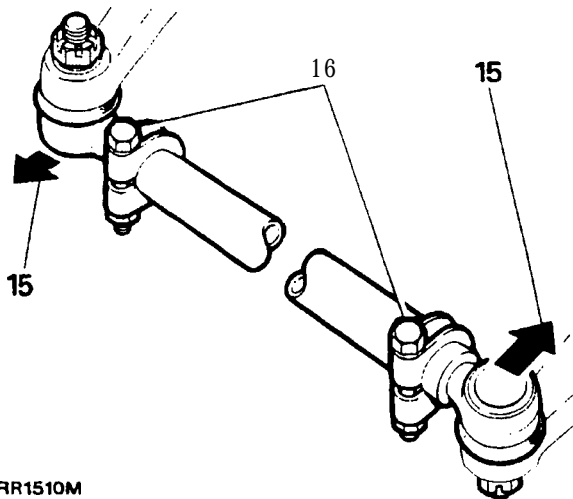

RR1510M

17. Reverse 1 and 2.

**CAUTION:** A new drag link must be fitted if the existing drag link is damaged or bent. No attempt should be made to repair or straighten it.

STEERING LOCK STOPS

Check and adjust

Checking

1. Measure the clearance between tyre wall and radius arm at full lock. This must be 20 mm (0.787 in).

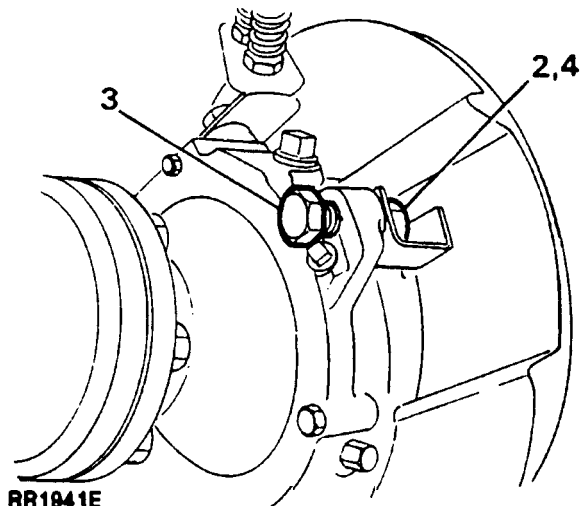

RR1041E

Adjusting

2. Loosen the stop bolt locknut.
3. Turn the stop bolt in or out as required.
4. Tighten the locknut.
5. Check the clearance between tyre wall and radius arm on each lock.

## FRONT WHEEL ALIGNMENT

## Check and adjust

## Checking

## Toe-out dimensions

**NOTE: No Adjustment is provided for castor, camber or swivel pin inclinations.**

1. Set the vehicle on level ground with the road wheels in the straight-ahead position.
2. Push the vehicle back then forwards for a short distance to settle the linkage.
3. Measure the toe-out at the horizontal centre-line of the wheels.
4. Check the tightness of the clamp bolt fixings for the correct torque (see section 06-Torque values).

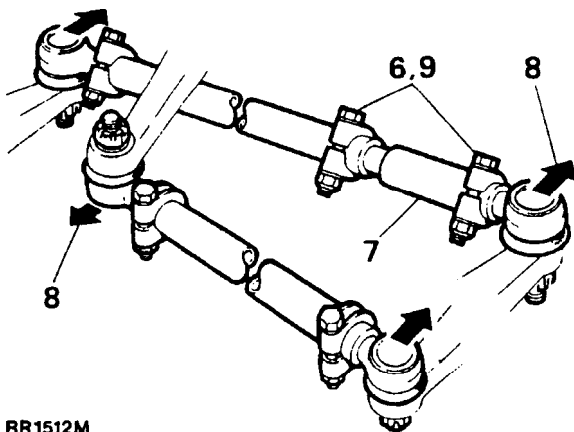
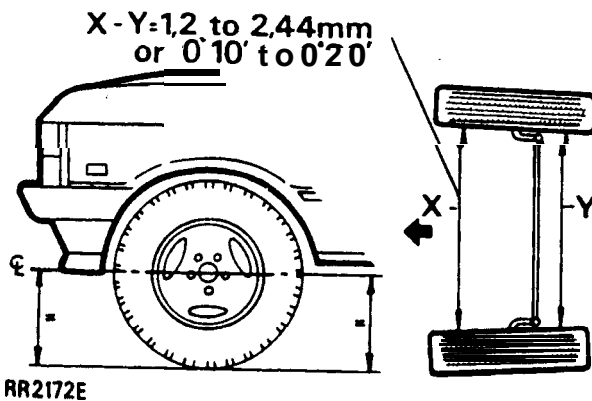

## Adjusting

6. Loosen the adjuster sleeve clamp.
7. Rotate the adjuster to lengthen or shorten the track rod.
8. Check the toe-out setting as in instructions 1 to 4. When the toe-out is correct lightly tap the steering linkage ball joint, in the directions illustrated, to the maximum of their travel to ensure full unrestricted working travel.
9. Finally, tighten the clamp bolts to correct torque (see section 06-Torque values).