

## BODY REPAIRS, GENERAL INFORMATION

The Range Rover body consists of a steel frame to which alloy outer panels are attached. The cowl panel, front fenders, side door outer panels, body side outer panels and roof are made from a special light magnesium-aluminium alloy.

The manufacture of body panels from aluminium has two distinct advantages, the first of which is a much better resistance to corrosion, the second being a decrease in the gross vehicle weight.

Aluminium panels can be effectively repaired using the 'Argon Arc' process of welding, because the afore mentioned is a specialist operation it is necessary that only a skilled operator or specialist body shop undertake such repairs.

Under certain conditions it may not be practical to repair an exterior damaged panel, if this is the case, then panels can be easily removed and replaced with new ones (refer to the appropriate part of the Body section for panel removal and refit).

### Panel beating

1. Aluminium alloy panels can be beaten out after accidental damage in the same way as sheet steel. However, under protracted hammering the material will harden, and then it must be annealed to prevent the possibility of cracking. This is quite easily done by the application of heat, followed by slow air-cooling, but as the melting point is low, heat must be applied slowly and carefully.

**CAUTION:** Before applying heat to any panel ensure that the panel is clean and free from underseal and that the area to be worked on is well clear of any combustible materials. Ensure that all necessary precautions are taken against fire. IF HEAT IS TO BE APPLIED TO THE REAR RIGHT HAND FENDER, THE FENDER MUST FIRST BE REMOVED AS A FUEL EXPANSION TANK IS LOCATED BETWEEN THE FENDER AND INNER BODY SIDE.

## Welding

**CAUTION:** The battery ground lead **MUST** be disconnected before commencing welding. IF WELDING IS TO BE CARRIED OUT ON THE REAR RIGHT HAND FENDER, THE FENDER MUST BE REMOVED, AS A FUEL EXPANSION TANK IS LOCATED BETWEEN THE FENDER AND INNER BODY SIDE.

1. Clean off all grease and paint, dry thoroughly and then clean the edges to be welded, and an area at least half an inch on either side of the weld, with a stiff wire scratch brush or wire wool. Cleanliness is essential. Also clean the welding rod or strip with steel wool.
2. It is strongly recommended that a few welds are made on scrap metal before the actual repair is undertaken if the operator is not already experienced in welding aluminium and its alloys.
3. Use only 5 per cent magnesium aluminium welding rod (5 Mg/A).

### Welding tears and patching

1. If a tear extends to the edge of a panel, start the weld from the end away from the edge and also at this point drill a small hole to prevent the crack spreading, then work towards the edge.
2. When welding a long tear, or making a long welded joint, tack the edges to be welded at intervals of from 2 in to 4 in (50 to 100mm) with spots. This is done by melting the metal at the starting end and fusing into it a small amount of the filler rod, repeating the process at the suggested intervals. After this, weld continuously along the joint from right to left, increasing the speed of the weld as the material heats up.
3. When patching, cut the patch to the correct shape for the hole to be filled, but of such sizes as to leave a gap of 1/32 in (0.80mm) between it and the panel, and then weld as described above. Never apply an 'overlay' patch.

## Spot welding

1. **spot welding** is mainly used in the manufacture of the Range-Rover inner steel body frame and exterior magnesium-aluminium alloy panels, and is a process which can be carried out satisfactorily by the use of the proper apparatus in a specialist body shop. Aluminium and its alloys are very good conductors of heat and electricity, and thus it is most important to maintain the right conditions for successful spot welding. The correct current density must be maintained, and so must the 'dwell' of the electrodes. Special spot welding machines have been developed, but they are expensive, and though the actual work can be carried out by comparatively unskilled labour, supervision and machine maintenance must be in the hands of properly qualified persons.

## Riveting

1. Where both sides of the metal are accessible and it is possible to use an anvil or 'dolly' solid aluminium rivets may be used, with a suitable punch or 'pop' to ensure clean rounded head on the work. For riveting blind holes, 'pop-rivets' must be used. These are inserted and closed by special 'Lazy-Tong' 'pop-rivet' pliers.

## PAINTWORK

## General Information

Before undertaking any paintwork process on the exterior body of Range Rover, firstly ascertain which is the best method of repair either by panel repair or replacement.

The initial preparation of a panel is very important to ensure that when finished it is of a standard that meets and matches existing bodywork. Panels must be thoroughly degreased with Berger Preclean 802.0516 or a suitable equivalent, any unsound paint to be stripped using Berger Double strength Meltic 301.8051. Always refer to the paint manufacturers instructions.

Paintwork processes should be performed by a specialist bodyshop where paint spraying can be undertaken in a controlled environment whereby temperatures are kept constant and the atmosphere dust free.

The flow chart on the following page gives a guide to preparing and painting a panel. Wherever possible refer to the Berger Vehicle Refinishes Product Data and Application Sheets for further information.

SUBSTRATE

| ALUMINIUM PANELS   |   |
|--|---|
| PANEL REPAIR   | REPLACEMENT PANEL   |
| <p><b>PREPARATION</b></p> <p>Vet for using P60 Grade paper or dry and using P240 grit discs.</p>   | <p>Wet flat using P60 Grade paper or dry sand using P240 grit discs. Care must be taken to avoid cutting through to bare aluminium.</p> |
| <p><b>BODY FILLING</b></p> <p>If filling is required, thoroughly abrade bare aluminium area to be filled and apply Standox Polyester stopper 430-5029.</p>   | <p>If filling is required, fill small indentations with Standox Polyester stopper 430-5029.</p>   |
| <p><b>ETCHING</b></p> <p>Etch the bare aluminium and filler with auto-speed self etch primer 414-1171, mixed 1:1 with activator 301-7995. Apply one coat and allow to dry for approximately 20 minutes. Recoat within 1 hour.</p>  | <p>This process is not required if the original electrocoat primer is in sound condition.</p> <p><b>IF NOT</b></p>                      |
| <p><b>PRIMING</b></p> <p>To obtain maximum adhesion and excellent build, apply Standox 2K 4:1 full primer 405-0381. Coats of 30-40 microns can be wet flatted with P60 grade paper after 45 minutes at 20°C.</p>   |   |
| <p><b>COLOUR COATING</b></p> <p>Apply either Standox 2K Standocryl or Standox Metallic Basislack to the colour required. Hardeners and thinners will vary depending upon system employed, conditions available, temperature and size of vehicle etc. Refer to paint manufacturers Technical Information Sheet for correct selection.</p> |   |

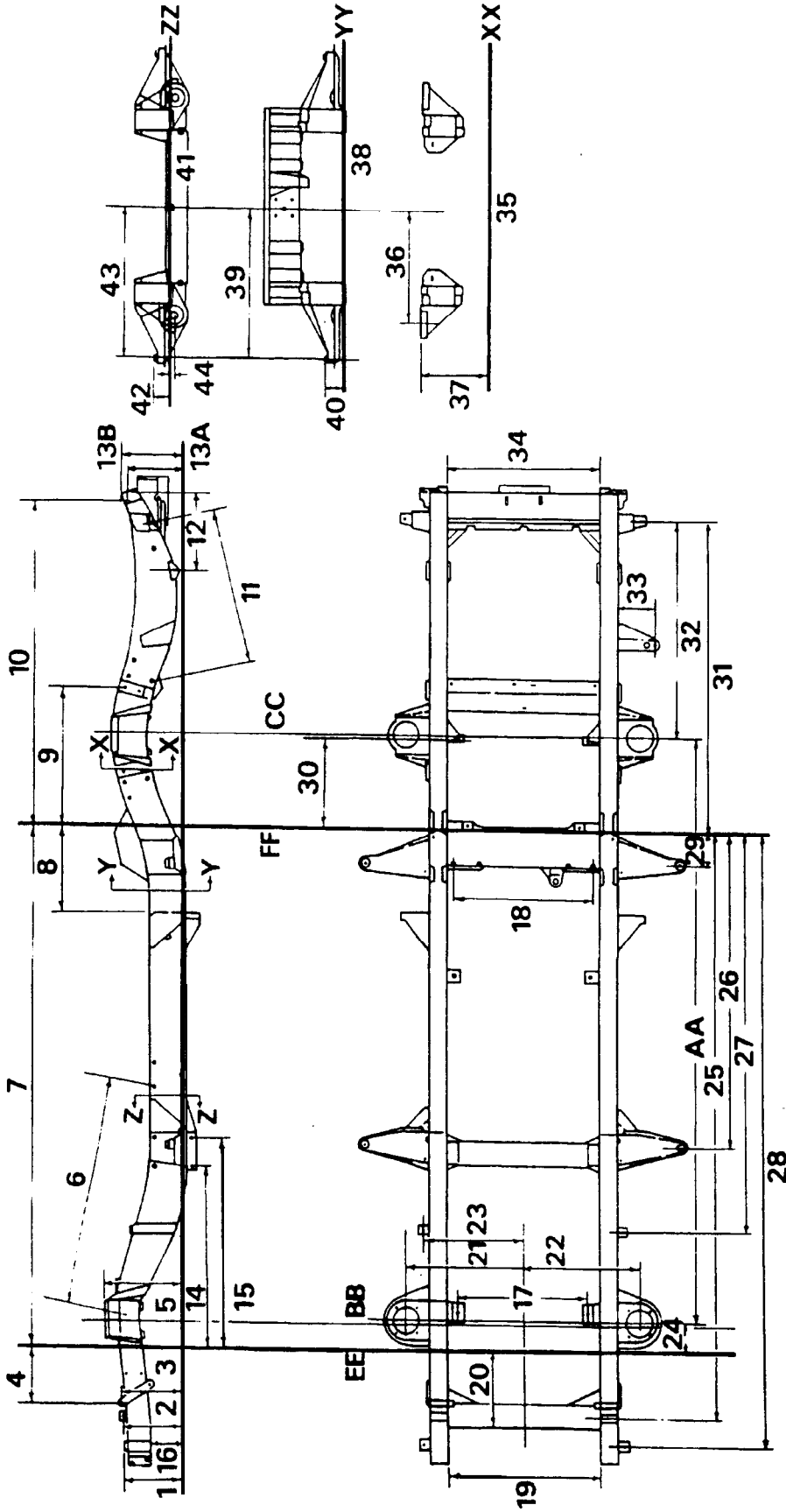

REVISED: APR. 87

RR2016E

**CHASSIS FRAME**  
Alignment check

|  | Diagram reference                           | millimetres        | inches             |
|--|---|--------------------|--------------------|
|  | AA Wheelbase-Reference dimension            | 2540.00            | 100.000            |
|  | BB Centre line of front axle                |                    |                    |
|  | c c Centre line of rear axle                |                    |                    |
|  | DD Frame datum line                         |                    |                    |
|  | EE Side member datum line                   |                    |                    |
|  | FF Datum line                               |                    |                    |
|  | 1 (with mounting washers)                   | 254.00 $\pm$ 0.63  | 10.000 $\pm$ .025  |
|  | (without washers)                           | 263.525 $\pm$ 1.91 | 10.375 $\pm$ .075  |
|  |   | - 0.63             | - .025             |
|  | 2   | 261.11 $\pm$ 2.54  | 10.180 $\pm$ .100  |
|  | 3   | 266.70 $\pm$ 2.54  | 10.500 $\pm$ .100  |
|  | 4   | 237.74 $\pm$ 1.27  | 9.360 $\pm$ .050   |
|  | 5   | 327.81 $\pm$ 2.54  | 12.906 $\pm$ .100  |
|  | 6   | 979.93 $\pm$ 1.27  | 38.580 $\pm$ .050  |
|  | 7   | 2244.72 $\pm$ 2.54 | 88.375 $\pm$ .100  |
|  | 8   | 356.74 $\pm$ 2.54  | 14.045 $\pm$ .100  |
|  | 9   | 605.15 $\pm$ 2.54  | 23.825 $\pm$ .100  |
|  | 10  | 1405.38 $\pm$ 2.54 | 55.330 $\pm$ .100  |
|  | 11  | 694.44 $\pm$ 2.54  | 27.340 $\pm$ .100  |
|  | 12  | 338.83 $\pm$ 2.54  | 13.340 $\pm$ .100  |
|  | 13A   | 222.25 $\pm$ 5.08  | 8.750 $\pm$ .200   |
|  | 13B   | 240.54 $\pm$ 2.54  | 9.470 $\pm$ .100   |
|  | 14 Reference dimension                      | 794.91             | 31.296             |
|  | 15 To face of boss                          | 935.43 $\pm$ 2.54  | 36.828 $\pm$ .100  |
|  | 16 Frame datum to underside of cross-member | 150.79             | 5.937              |
|  | 17  | 535.94 $\pm$ 2.54  | 21.100 $\pm$ .100  |
|  | 18  | 590.55 $\pm$ 0.64  | 23.250 $\pm$ .025  |
|  | 19 Check figure                             | 630.93 $\pm$ 1.27  | 24.840 $\pm$ .050  |
|  | 20  | 344.17 $\pm$ 1.27  | 13.550 $\pm$ .050  |
|  | 21  | 485.77 $\pm$ 2.54  | 19.125 $\pm$ .100  |
|  | 22  | 485.77 $\pm$ 2.54  | 19.125 $\pm$ .100  |
|  | 23  | 414.32 $\pm$ 2.54  | 16.312 $\pm$ .100  |
|  | 24  | 129.03 $\pm$ 2.54  | 5.080 $\pm$ .100   |
|  | 25  | 2544.44 $\pm$ 0.25 | 100.175 $\pm$ .010 |
|  | 26  | 1355.34 $\pm$ 0.38 | 53.360 $\pm$ .015  |
|  | 27  | 1722.04 $\pm$ 0.38 | 67.797 $\pm$ .015  |
|  | 28  | 2663.44 $\pm$ 0.38 | 104.860 $\pm$ .015 |
|  | 29  | 144.09 $\pm$ 0.38  | 5.673 $\pm$ .015   |
|  | 30  | 400.48 $\pm$ 2.54  | 15.767 $\pm$ .100  |
|  | 31  | 1333.88 $\pm$ 0.38 | 52.515 $\pm$ .015  |

Continued

|    |                     | millimetres | inches |
|----|---------------------|-------------|--------|
| 32 | Reference dimension | 925.49      | 36.437 |
| 33 | Reference dimension | 147.62      | 5.812  |
| 34 | Reference dimension | 635.00      | 25.000 |

## SECTION XX

|    |                     |                   |                   |
|----|---------------------|-------------------|-------------------|
| 35 | Frame datum line DD |                   |                   |
| 36 |                     | 488.95 $\pm$ 2.54 | 19.250 $\pm$ .100 |
| 37 |                     | 295.27 $\pm$ 2.54 | 11.625 $\pm$ .100 |

## SECTION YY

|    |                     |                        |                        |
|----|---------------------|------------------------|------------------------|
| 38 | Frame datum line DD |                        |                        |
| 39 |                     | 660.40 $\pm$ 0.17      | 26.000 $\pm$ .007      |
| 40 |                     | MO.95 + 1.91<br>- 0.63 | 3.187 + .075<br>- .025 |

## SECTION ZZ

|    |                     |                        |                        |
|----|---------------------|------------------------|------------------------|
| 41 | Frame datum line DD |                        |                        |
| 42 |                     | 80.95 + 1.91<br>- 0.63 | 3.187 + .075<br>- .025 |
| 43 |                     | 660.4 $\pm$ 0.17       | 26.000 $\pm$ .007      |
| 44 |                     | 9.525 $\pm$ 2.54       | 0.375 $\pm$ .100       |

## BODY

## Introduction:

The information which follows is concerned solely with the 'Monocoque' assembly of the inner body shell on Range Rover models.

Body repairs often require the removal of mechanical and electrical units and associated wiring. Where necessary, reference should be made to the relevant section of the Repair Manual for removal and refitting instructions.

The inner body shell is of 'Monocoque' construction and to gain access to the repair area, it may be necessary to remove exterior body panels, all exterior body panels are bolted to the inner body shell to facilitate easier panel removal and replacement or repair.

It is expected that a repairer will select the best and most economic repair method possible, making use of the facilities available. The instructions given are intended to assist a skilled body repairer by expanding approved procedures for panel replacement with the objective of restoring the car to a safe running condition and effecting a repair which is visually acceptable.

## WELDING

The following charts and illustrations show the locations and types of weld for securing the body side assembly, tailgate frame assembly and the front valance and wheel arch assembly. Before undertaking any spot weld joints to the inner body, it is advisable to make a test joint using offcuts of the damaged components, and to use this test piece to perform a weld integrity test.

Spot welding is satisfactory if the joints do not pull apart. If the weld pulls a hole or tears the metal the weld is satisfactory. It is defective if the weld joint pulls apart or if there are signs of burning, porosity or cracking evident.

## PREPARATION

Thoroughly clean all areas to be welded, remove any sealants and corrosion protectives from around original panels. Align and clamp all new panels in position and check relationship to one another.

Continued

INNER BODY SHELL ASSEMBLY

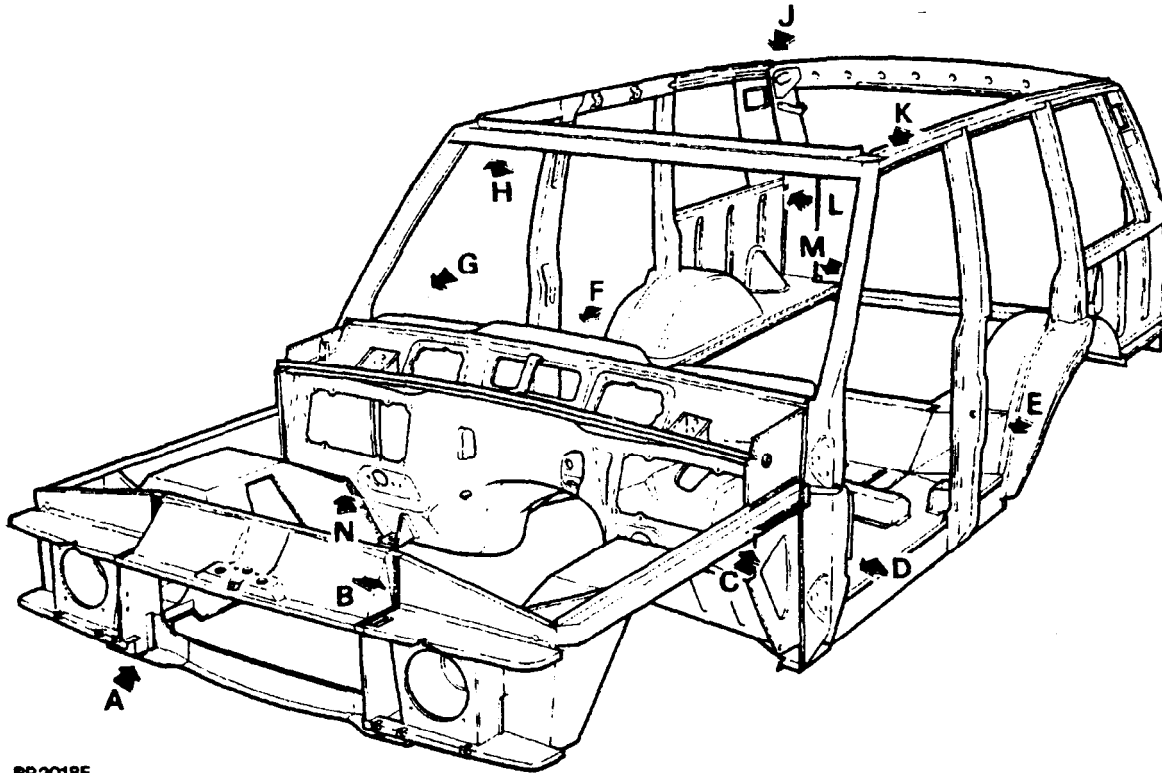

RR2018E

| LOCATION   | FACTORY JOINT (minimum number of spot welds quoted) |
|--|---|
| A. Front cross member to valance and wheel arch assembly       | 6 spot welds, 20mm pitch                            |
| B. Hood locking platform to valance and wheel arch assembly    | 10 spot welds, 25mm pitch                           |
| C. Valance and wheel arch assembly to dash and tunnel assembly | 16 spot welds, 25mm pitch                           |
| D. Body side complete to dash and tunnel assembly              | 10 spot welds, 65mm pitch                           |



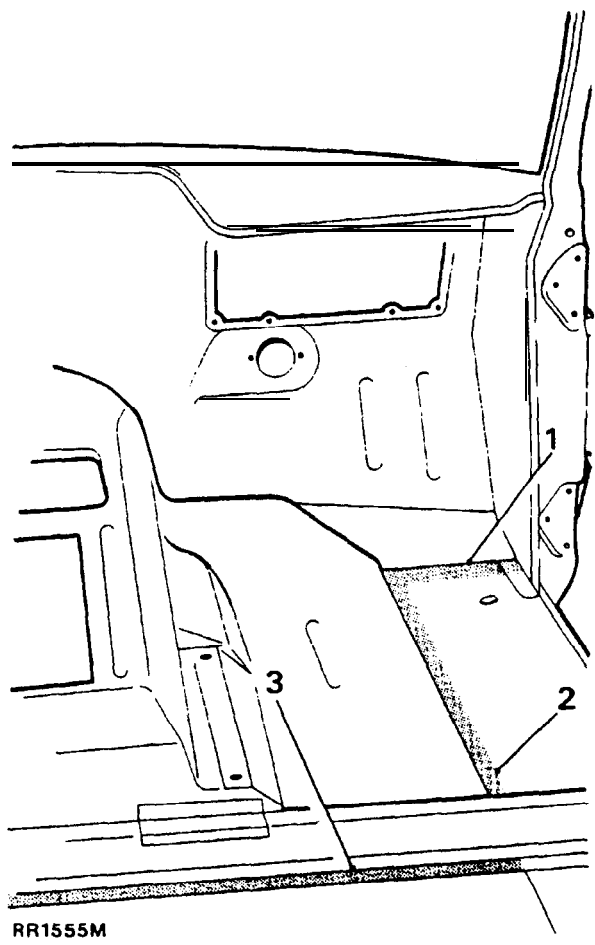
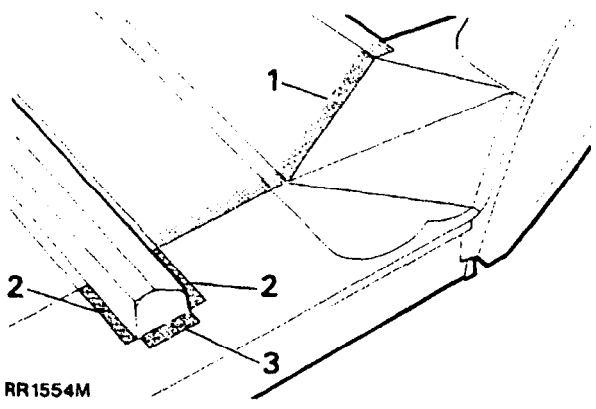

LOCATION E

LOCATION F

| LOCATION  | FACTORY JOINT (minimum number of spot welds quoted)  |
|---|--|
| E. 1. Body side complete to heelboard panel assembly.<br>2. Body side complete to dash and tunnel assembly complete.<br>3. Body side complete to dash and tunnel assembly                 | 14 spot welds, 35mm pitch<br><br>10 spot welds, 25mm pitch<br><br>3 spot welds, 30mm pitch |
| F. 1. Body side complete to dash and tunnel assembly complete<br>2. Body side complete to dash and tunnel assembly complete<br>3. Body side complete to dash and tunnel assembly complete | 7 spot welds, 30mm pitch<br><br>18 spot welds, 40mm pitch<br><br>30 spot welds, 34mm pitch |

Continued

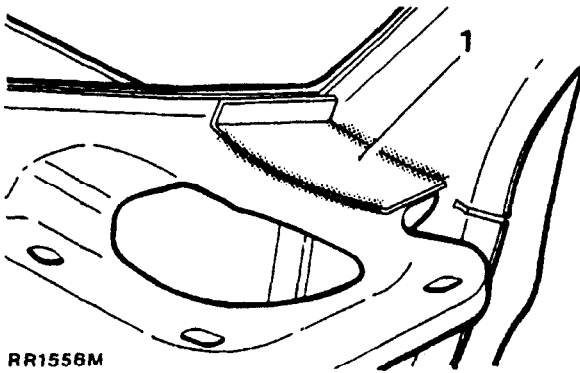

LOCATION G

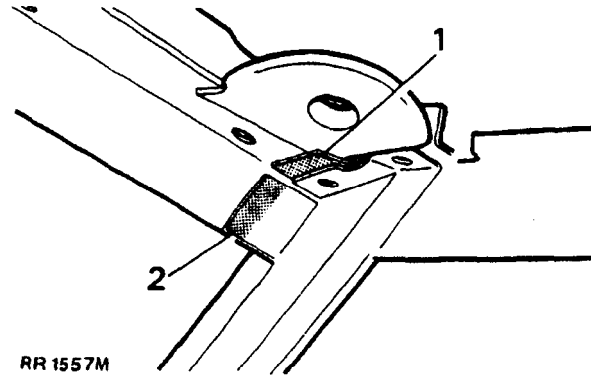

LOCATION H

| LOCATION  | FACTORY JOINT (minimum weld requirement quoted)                 |
|---|---|
| G. 1. Reinforcement plate to dash and tunnel assembly and body side assembly complete   | CO, weld, 2 places 75mm long each weld                          |
| H. 1. Body side complete to roof header panel assembly (internal joint)<br>2. Body side complete to roof header panel assembly (internal joint) | 3 spot welds, 15mm pitch<br><br>3 spot welds, <b>15mm</b> pitch |

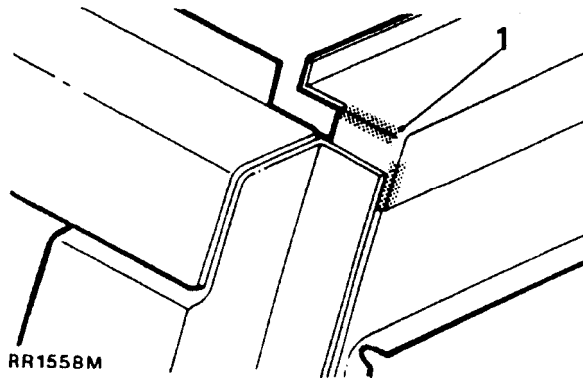

LOCATION J

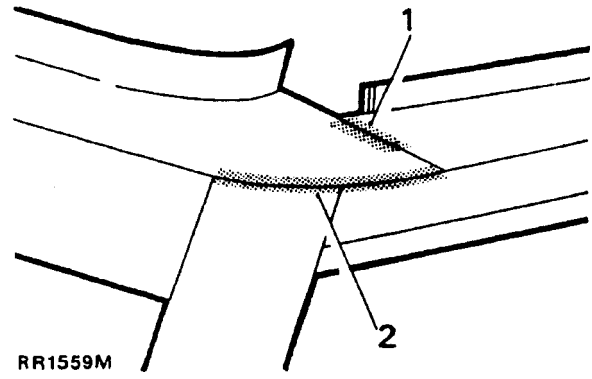

LOCATION K

| LOCATION  | FACTORY JOINT (minimum weld requirement quoted)   |
|---|---|
| I. 1. Body side complete to rear tailgate frame assembly  | CO <sub>2</sub> weld, one run 40mm long   |
| K. 1. Body side complete to roof header panel assembly (external joint)<br>2. Body side complete to roof header panel assembly (external joint) | CO <sub>2</sub> weld, one run 20mm long<br><br>CO <sub>2</sub> weld, one run 100mm long |

Continued

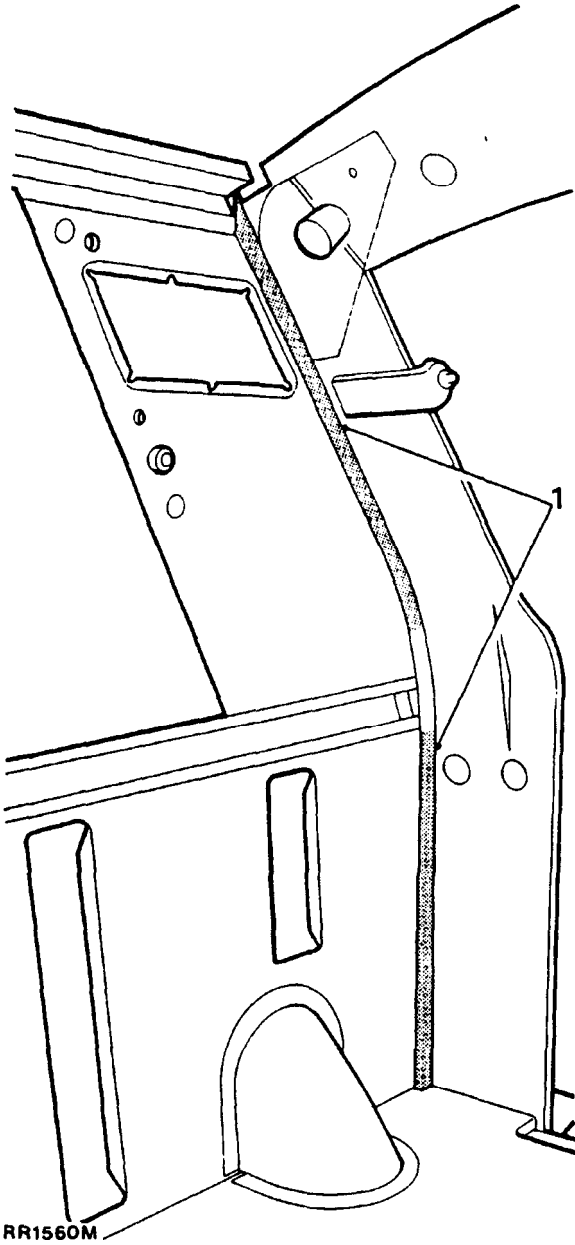

LOCATION L

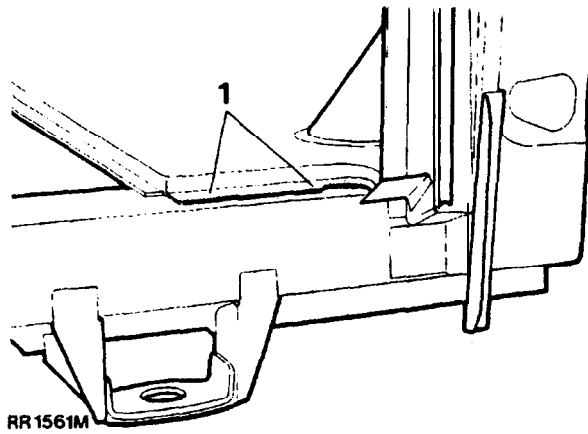

LOCATION M

| LOCATION  | FACTORY JOINT (minimum weld requirement quoted) |
|---|---|
| L. 1. Body side complete to rear tailgate side member         | 32 spot welds, 30mm pitch                       |
| M. 1. Body side complete to rear tailgate bottom cross member | CO <sub>2</sub> weld, 2 runs 40mm long          |

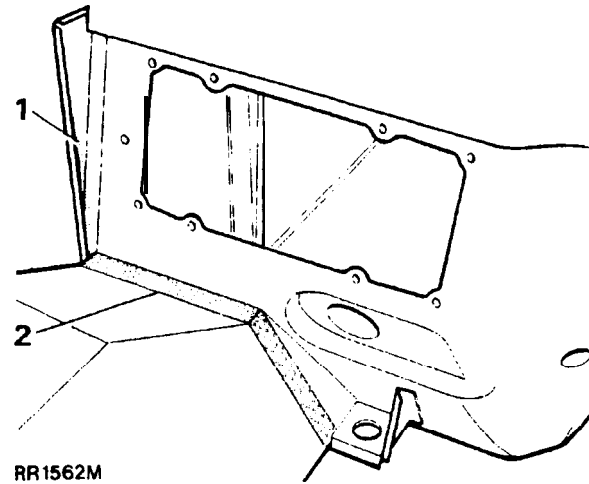

LOCATION N

| LOCATION   | FACTORY JOINT (minimum number of spot welds quoted)       |
|--|---|
| N. 1. Valance and wheel arch assembly to dash and tunnel assembly<br>2. Valance and wheel arch assembly to dash and tunnel assembly. | 4 spot welds, 45mm pitch<br><br>15 spot welds, 25mm pitch |

## HEADLINING AND ROOF PANEL

## Remove and refit

## Removing

## Headlining

1. Remove the two roof lamp assemblies.
2. Remove the rear view mirror and mounting bracket.
3. Remove the two sun visors and centre retaining bracket.
4. Remove the front and rear passenger grab rails.
5. Pry out the two plastic retaining clips securing the centre of the headlining to the roof panel.
6. With assistance support the front of the headlining while releasing the two rear fixings above the rear quarter light glass.
7. While the headlining is still being supported pry out the two plastic retaining clips securing the rear end of the headlining, located adjacent to the upper tailgate hinges.

**CAUTION:** To avoid damage and to assist in the removal of the headlining from the vehicle, slightly flex the headlining as shown in the illustration below.

8. Lower the headlining and disconnect the electrical leads from the rear radio speakers, remove the headlining from the vehicle.

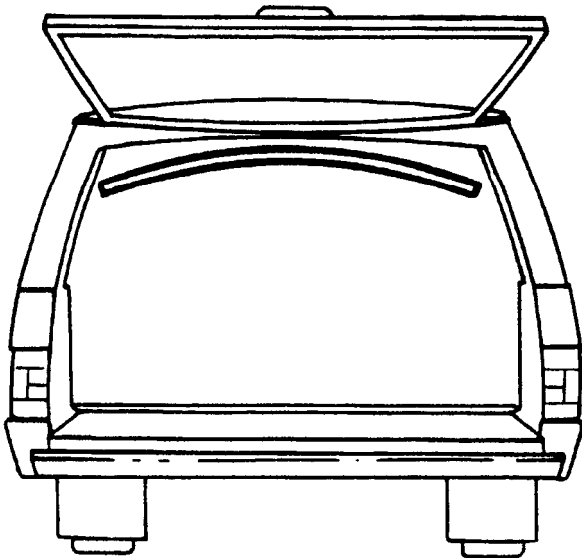

RR2187E

## Roof panel

9. Remove the screws (with washers) from around the inner edge of the roof panel.
10. With assistance lift the roof panel from the body, remove any previous sealing compounds from around the edge of the roof panel and body.

## Refitting

11. Apply a waterproof sealant to roof and body mating faces.
12. Reverse the removal instructions 1 to 9.

## HOOD-COWL PANEL-FRONT FENDER

## Remove and refit

## Removing

**CAUTION:** The assisted hood lift mechanism alone will not retain the hood in its fully open position. Always secure the hood stay to support an open hood.

1. Open the hood and disconnect the battery negative terminal.
2. Disconnect the under-hood lamp electrical leads.
3. Disconnect the windscreen washer tube at the 'T' joint.
4. Release the four bolts securing the hood to the hinges, note the ground strap located under the upper left hand hood fixing, with assistance lift the hood clear of the vehicle.

## Cowl panel

5. Remove the wiper arms and two nuts securing the wheel boxes to the cowl panel and remove the two exterior sealing rubbers.
6. Remove the nine cross-head screws securing the front of the cowl panel.
7. Remove the four bolts (with spring and plain washers) retaining the cowl panel to the top of the fenders, retrieve the nylon spacing washers from between cowl panel and fender.

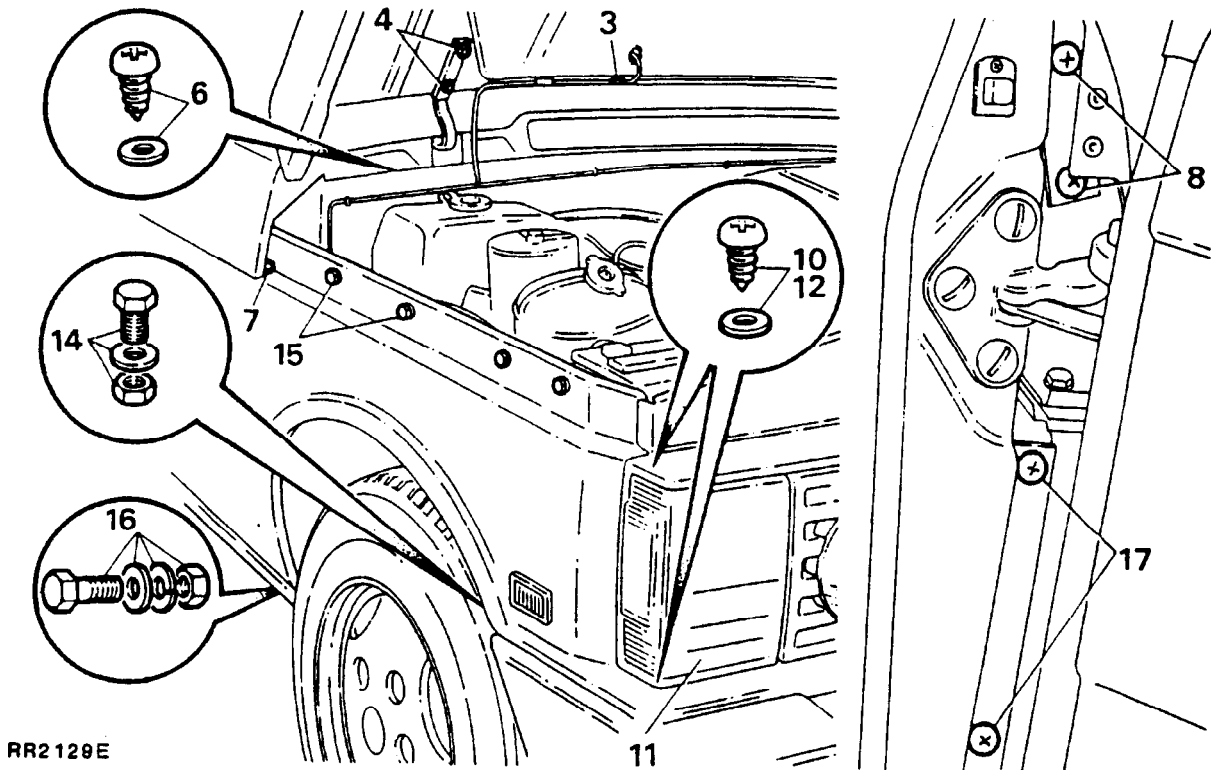

RR2129E

8. Remove the four cross-head screws retaining the panel to the 'A' post mounting brackets located above the front door hinges.
9. With assistance place a tube over each of the hinges and lower to enable the cowl panel to be fed over the hinges, carefully return the hinges to their upright position.

16. Remove the two bolts (with plain washers) securing the sill finishing strip to the bottom of the fender.
17. Remove the two cross-head screws securing the fender to the mounting bracket attached to the 'A' post located in between the front door hinges.

**Front fender**

**Refitting**

10. Remove the two cross-head screws from the top of the front side light assembly, maneuver the assembly out of the two bottom location holes.
11. Remove the bulb holder waterproof cover, depress the two retaining clips and withdraw the bulb holder from the rear of the lamp unit. Remove the lamp unit.
12. Remove the two screws (with plain washers) from the bottom of the side light recess.
13. Remove the three fixings securing the bumper wrap around end cap and remove the moulding from the bumper.
14. Remove the bolt which secures the end of the spoiler to the front of the wheel arch, located forward of the road wheel at the bottom of the fender.
15. Remove the five nuts and bolts (with plain and spring washers) securing the top edge of the fender to the wheel arch and valance assembly.

**Front fender**

18. Apply a suitable underseal to the inner face of the fender and a waterproof sealant to the fender to wheel arch/valance mating faces.
19. Ensure that before final tightening of the fender securing bolts the fender aligns with the edge of the front door.
20. Reverse remaining fender removal instructions.

**Continued**

**Cowl panel**

21. Lower the hinges to enable the cowl panel to be fitted.
22. Fit the securing bolts ensuring that any nylon spacers previously removed are refitted in their original position.
23. Using a soft blunt implement ease the windscreen rubber up onto the top of the cowl panel.
24. Reverse the remaining cowl panel removal instruction.

**Hood**

25. Fit the hood ensuring that before final tightening of the securing bolts, the engine ground strap is refitted to the forward bolt of the left hand hinge, and that the hood aligns with the cowl panel, fender and front grille, adjust the hood at the hinges as necessary.
26. Reverse the remaining removal instructions.

**NOTE:** An engine ground strap is attached to the forward bolt of the left hand hinge and must be refitted when the hood is re-bolted to the hinges.

6. With assistance lift the hood clear of the hinges and store safely to one side, cover hood to protect paintwork.

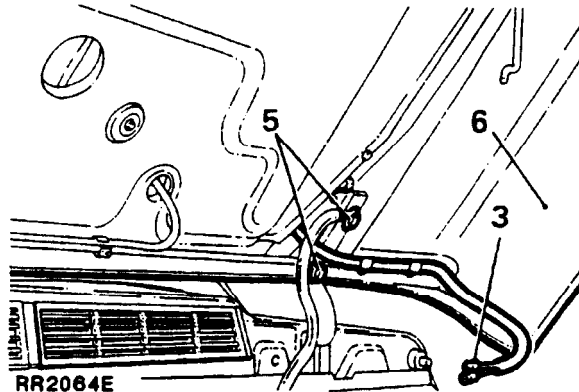
**ASSISTED HOOD LIFT****Remove and refit****Removing**

**CAUTION:** The assisted lift mechanism of the hood eases the hood opening and lift procedure. When the hood is fully open, secure the hood stay in position. The assisted lift mechanism alone **WILL NOT** retain the hood in its upright position.

1. Carefully pry the wiper arms off the spindle bosses, noting their position for re-assembly.
2. Raise the hood and disconnect the battery negative terminal.
3. Disconnect the electrical lead to the hood illumination lamp.
4. Disconnect the screen washer fluid feed pipe at the 'T' joint, remove the feed pipe from the hood retaining clip.

**NOTE:** The removal of the hood will require the assistance of a second person.

5. Release the four bolts (with plain washers) securing the hood to the hinges.

7. Remove the two wiper box wheel nuts and rubber spacers.
8. Remove the four fixings securing the cowl panel to the front fenders, the front two fixings are accessible from the front of the cowl panel, access to the rear two fixings is gained by opening the front doors. Note the nylon spacing washers at each bolt.

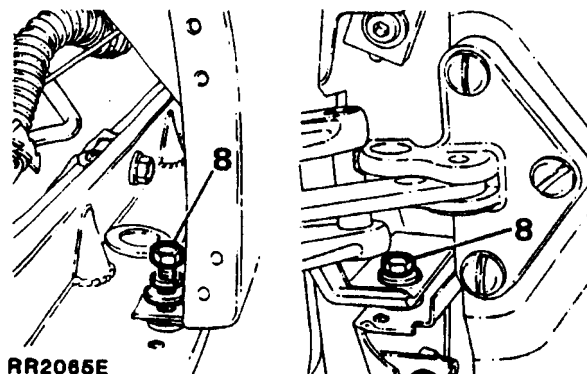

9. Remove the nine cross-head screws from the front of the cowl panel water channel.



10. Place extension tubes over each hood hinge, with assistance lower the hinges, maneuver the cowl panel off the wiper arm shaft bosses and along the tubes until the panel is clear of the vehicle. Place the panel to one side and cover to protect paintwork.

**WARNING:** Gradually let the torsion bar spring tension return the hinges to their upright position to prevent the possibility of personal injury or damage to the vehicle.

11. Place an extension tube over the hinge, lower the hinge until the stop bracket can be removed, withdraw the bracket and gradually allow the hinge to return to its upright position.

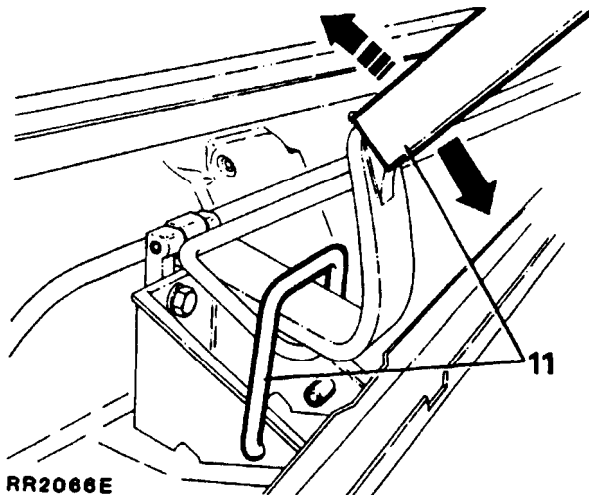

12. Release the torsion bar from the retaining clip.
13. Maneuver the torsion bar until it can be released from the hinge.
14. Release the torsion bar from the retaining bracket.

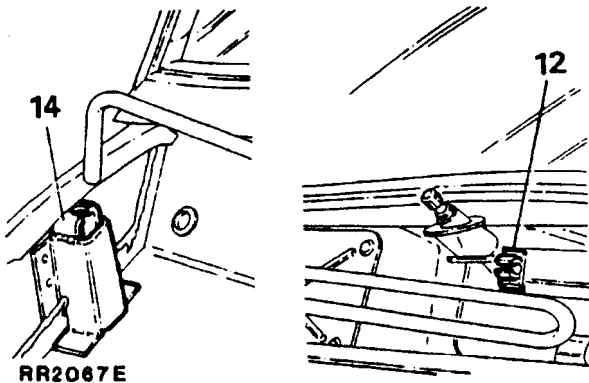

15. Remove the two bolts (with plain washers) securing the hinge to its mounting bracket.
16. Withdraw the hinge.

**Refitting**

17. Fit the hinge and securely tighten the two retaining bolts (with plain washers).
18. Fit the torsion bar ensuring that it is securely located in the retaining clip and bracket.
19. Reverse the remaining removal instructions.

**NOTE:** Fit the ground strap under the forward bolt of the left hand hinge.

20. Using a soft blunt implement ease the bottom lip of the windscreen seal up and over onto the face of the cowl panel.

## REAR CORNER PANEL AND FENDER

Remove and refit

**CAUTION:** IF A REPAIR IS BEING UNDERTAKEN ON OR AROUND THE AREA OF THE REAR RIGHT HAND FENDER AND HEAT IS TO BE APPLIED, THE FENDER MUST BE REMOVED, AS A FUEL EXPANSION TANK IS LOCATED BETWEEN THE FENDER AND INNER BODY SIDE.

## Removing

**NOTE:** Ensure the central locking system is de-activated to enable the fuel filler flap to be opened, disconnect the battery negative terminal.

1. Open the fuel filler flap and remove the three filler tube securing screws. (Right hand rear fender only)

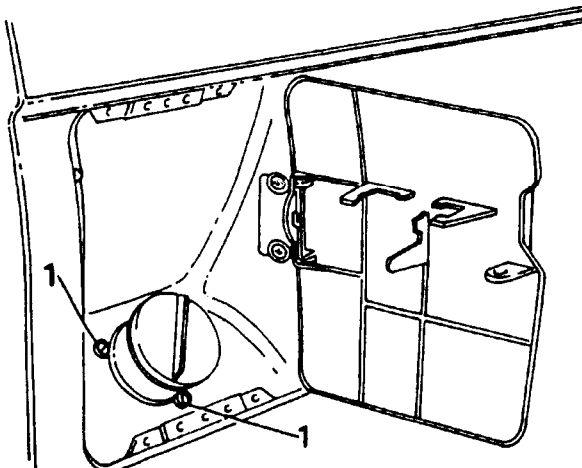

RR2130E

2. Remove the rear stowage area parcel shelf and spare wheel.
3. Remove the two nuts (with washers) securing the bumper wrap around end cap to the bottom of the corner panel.
4. Remove the single bolt securing the end cap to the bumper, accessible from behind the bumper.
5. Remove the fixings and release the rear tail light cluster from the rear corner panel and disconnect the electrical plug.
6. Drill out all the pop-rivets securing the corner panel to the tailgate frame.
7. Remove the two nuts and bolts securing the front of the fender to the 'D' post located beneath the wheel arch.
8. Release the single nut and bolt retaining the mud-flap bracket to the bottom of the fender.

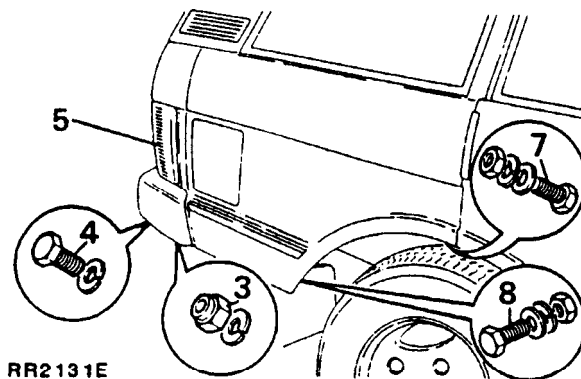

RR2131E

9. From inside the stowage area remove the five cross-head screws securing the top of the fender to the bodyside panel. If necessary fold the rear seat forward and remove the seat locking mechanism housing to gain access to the screw adjacent to the 'D' post.

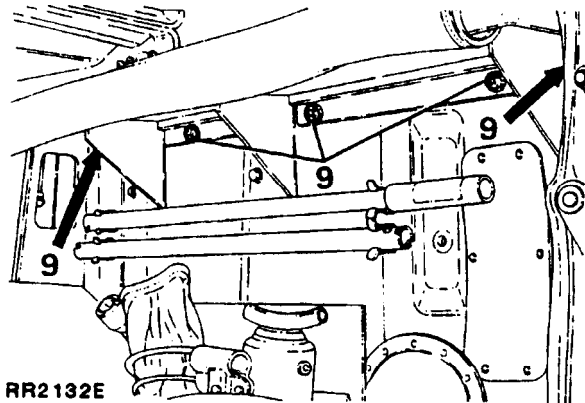

RR2132E

10. Remove the rear fender and corner panel complete.
11. Remove the seven bolts (with plain and spring washers) securing the fender to the corner panel and separate the two panels.

## Refitting

12. Assemble the corner panel to the rear fender, fit the bolts and ensure both panels align before final tightening.

13. Coat the underside of panels with a suitable underseal.
14. Fit the assembly to the vehicle ensuring that the door edge to fender edge and corner panel to lower tailgate are in alignment before the final tightening of screws and the fitting of pop-rivets.
15. Reverse the remaining removal instructions.

**FUEL FILLER FLAP**

**Remove and refit**

**Adjust**

**Removing**

**NOTE:** The fuel filler flap is locked when the vehicle central locking system has been activated, ensure the system has been de-activated before attempting to open the flap.

1. Open the fuel filler flap.
2. Release the two screws (with plain washers).
3. Withdraw the flap.

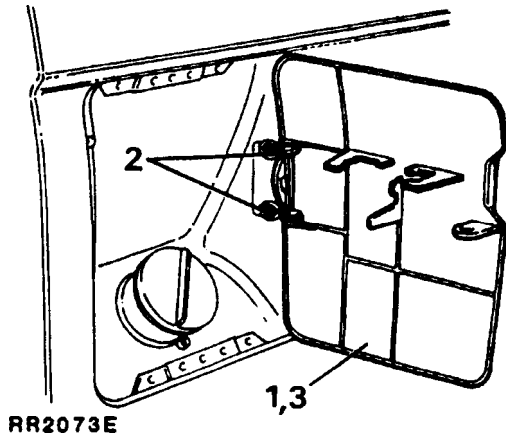

**Refitting**

4. Fit the flap, but do not fully tighten the screws at this stage.
5. Close the flap and check that the outer profile of the flap aligns with the rear fender, adjust by easing the flap in or out of the opening.
6. Open the flap and securely tighten the screws.

**REAR QUARTER PANEL-INTERIOR**

**Remove and refit**

**Removing**

**NOTE:** If removing the drivers side interior or exterior quarter panel it will be necessary to remove the spare wheel from the rear stowage area.

1. Detach the plastic cover from the upper seat belt guide bracket and remove the single bolt.
2. Remove the clip-on plastic cover from the seat belt inertia reel. Remove the retaining bolt and place the inertia reel to one side.
3. Release the two small cross-head screws securing the trim panel to the body side.
4. Ease the front of the trim panel from behind the quarter light glass rubber moulding.
5. Withdraw the panel from the vehicle.

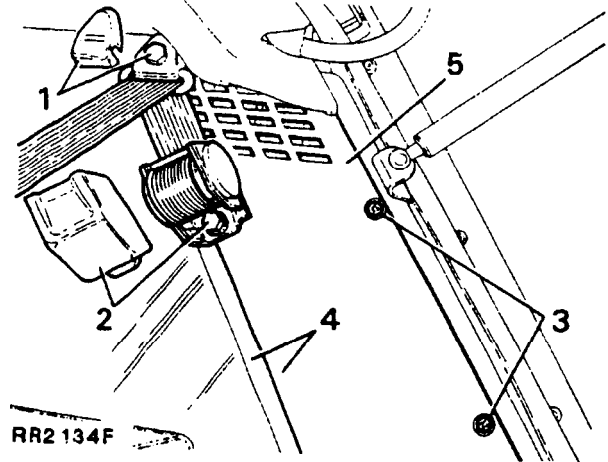

**Refitting**

6. Ease the top front edge of the trim panel (approximately the first 25mm, 1 inch) as close to the headlining as is possible under the lip of the rubber moulding.
7. Push the panel up behind the headlining until the cross head screw holes line up with their respective holes in the bodyside.
8. Using a soft blunt implement ease the rubber moulding lip over the remainder of the front of the trim panel.

**Continued**

9. Ensuring that the electrical harness is located in the channel at the rear of the trim panel fit the two crosshead screws.
10. Ensuring that the seat belt is not twisted fit the guide bracket and inertia reel, tighten the two bolts to the specified torque (see section 06-Torque values).
71. Refit the plastic cover to the guide bracket.

#### REAR QUARTER PANEL-EXTERIOR

Remove and refit

#### Removing

**NOTE:** If removing the drivers side interior or exterior quarter panel it will be necessary to remove the spare wheel from the rear stowage area.

1. Remove the rear seat belt inertia reel and guide bracket.
2. Remove the two crosshead screws and detach the interior quarter panel.
3. Remove the three nuts (with plain washers) securing the exterior quarter panel to the bodyside. The nuts are accessible through the large holes located adjacent to the rear quarter light.
4. Remove the four screws securing the quarter panel to the inside edge of the tailgate opening.
5. Withdraw the panel.

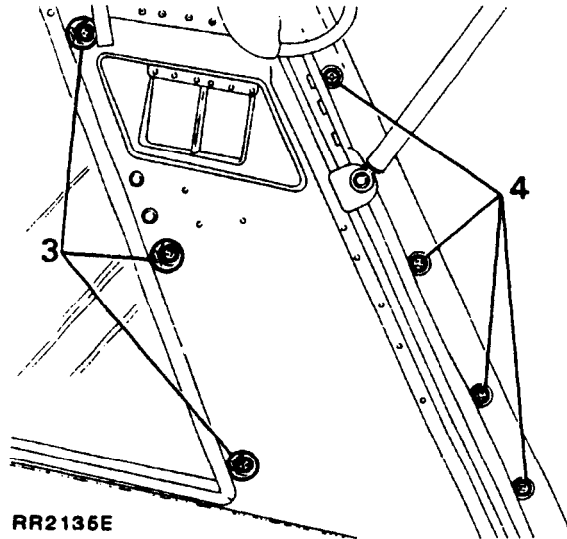

RR2136E

#### Refitting

6. Reverse the removal instructions.
7. Ensure that the seat belts, inertia reel and guide bracket bolts are tightened to the specified torque (see section 06-Torque values).

UPPER TAILGATE

Remove and refit

Removing

1. Disconnect the battery negative lead.
2. Remove the tailgate wiper arm.
3. Open the tailgate and remove the four screws securing the two rear screen electrical lead shrouds located at either end of the tailgate.
4. Maneuver the shroud away from the screen and out of the leadlining to reveal the electrical connections, disconnect the leads.

**WARNING:** If a tailgate stay is weak, DO NOT attempt to repair the unit. Fit a replacement.

5. Pry the two stays off the tailgate.
6. Remove the four hinge to tailgate screws.

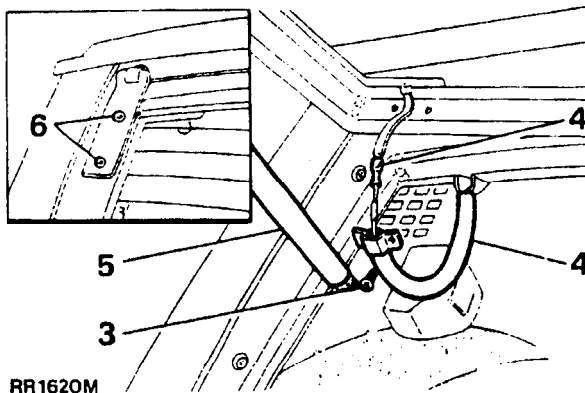

7. Lift the upper tailgate clear.

Refitting

8. Reverse the removal instructions.

UPPER TAILGATE-LOCK

Remove and refit

Removing

1. Remove the two cross-head screws securing the upper tailgate release handle.
2. Ease the sealing rubber away to reveal the single screw securing the centre of the release handle, remove the screw and detach the handle from the lock mechanism complete with key barrel.

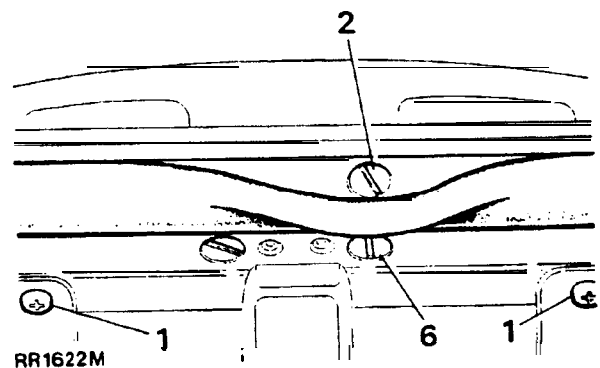

**NOTE:** At this stage the barrel can be removed from the handle by releasing the two small cross-head screws at the joint-face. Remove the retaining plate and release the spring and key barrel from its bore.

3. Release the eight screws and remove the operating rod covers located either side of the centre lock mechanism.
4. Remove the four screws and two nuts securing the lock catches to the sides of the tailgate.

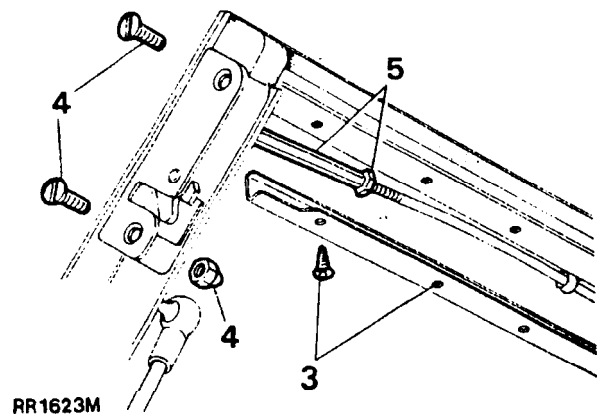

Continued

5. Release the two small locknuts on the operating rods and rotate the hexagonal connecting rod until the side catches can be removed.
6. Release the two screws securing the centre lock mechanism and remove the unit complete with operating rods.

**Refitting**

7. Reverse the removal procedure.
8. Adjustment of the side catches may be required after assembly, this is achieved by releasing the locknuts on the operating rods, and rotating the hexagonal link clockwise or counter-clockwise to shorten or extend the length of the operating rods.

**LOWER TAILGATE**

**Remove and refit**

**Removing**

1. Disconnect the battery negative terminal.
2. Carefully pull the electrical leads out of the bottom of the lower tailgate to reveal the snap connectors. Access to the leads is gained between the top of the bumper and bottom of the tailgate.

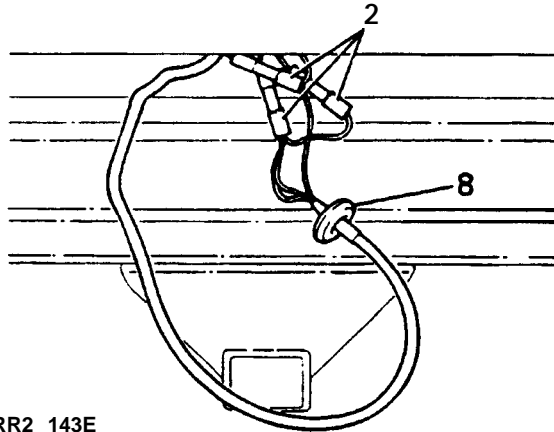

RR2 143E

3. Remove the four cross-head screws securing the sealing rubber around the tailgate hinge bolts.
4. Remove the fixings, tailgate to hinges.
5. Disconnect the check straps.
6. With assistance withdraw the tailgate.

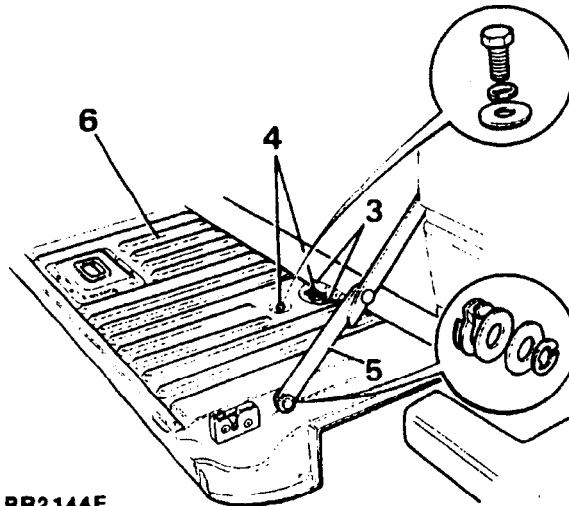

RR2144E

**Refitting**

7. Reverse 1 to 5.
8. Ensure that the rubber grommet is relocated in the bottom of the tailgate.

LOWER TAILGATE RELEASE MECHANISM

Remove and refit

Removing

1. Open and raise the upper tailgate.
2. Release and lower, the lower tailgate.
3. Lift the trim panel off the tailgate inner panel.
4. Remove the screws securing the lock cover plate.
5. Remove the cover plate complete with handle release mechanism.
6. Remove the two screws and detach the handle release actuator lever.
7. Remove the two nyloc nuts and detach the handle release retaining bracket.
8. Withdraw the handle release mechanism from the cover plate.

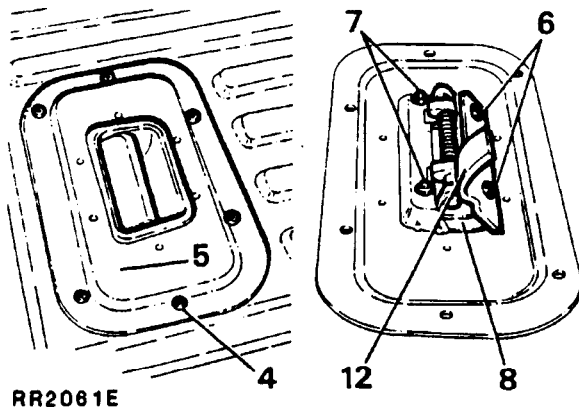

9. Release the spring clips securing the operating rods to the internal tailgate release mechanism.
10. Remove the screws securing the exterior locks at either side of the tailgate.
11. Withdraw the exterior locks with operating rods.

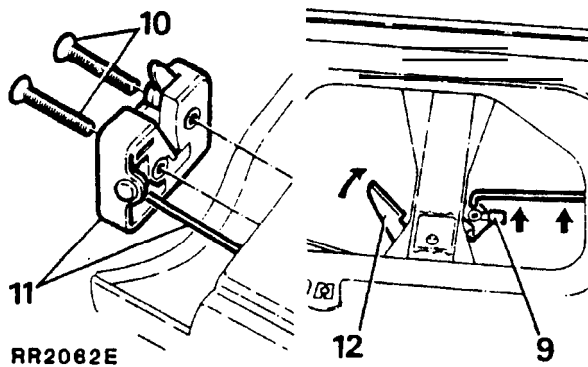

Refitting

12. Reverse the removal procedure, lightly grease the handle release actuator lever and internal tailgate operating lever.

LOWER TAILGATE STRIKER ADJUSTMENT

Adjust

1. Open and raise upper tailgate.
2. Open and lower, lower tailgate.
3. Release the striker and move in the appropriate direction, either add or subtract spacing washers between the striker and tailgate opening.
4. Adjustment is correct when outer profile of tailgate panel aligns with both rear body corner panels.

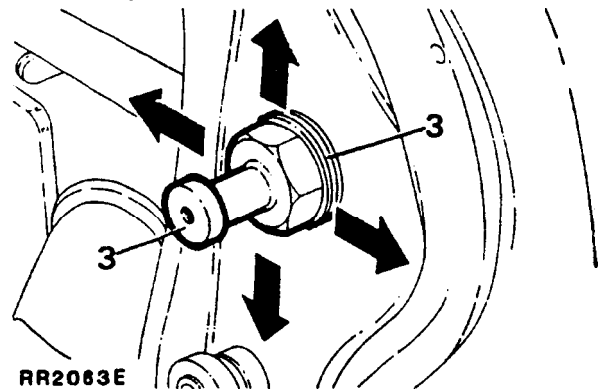

RADIATOR GRILLE

Remove and refit

Removing

1. Raise the hood and secure the hood support.
2. Depress the four upper retaining lugs and ease the grille forward.
3. Lift the grille upwards and withdraw it from the vehicle.

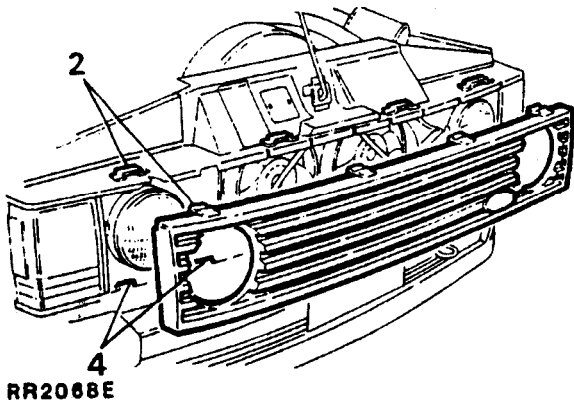

Refitting

4. Fit the radiator grille ensuring that the bottom lugs of the grille locate in their respective slots below the headlamp units.
5. Ease the grille rearwards and locate the upper retaining lugs.

FRONT DOOR

Remove and refit

Removing

1. Disconnect the battery negative lead.
2. Open the appropriate door to be removed.
3. Remove the two screws and detach the side trim panel from the front footwell.
4. Carefully pull the door wiring harness from above the dash until the electrical plugs are exposed.
5. Disconnect the electrical plugs and feed them through the opening in the 'A' post.
6. Drive out the roll pin from the door check strap.
7. With assistance support the door and remove the screws, securing door to hinges.
8. Lift the door clear.

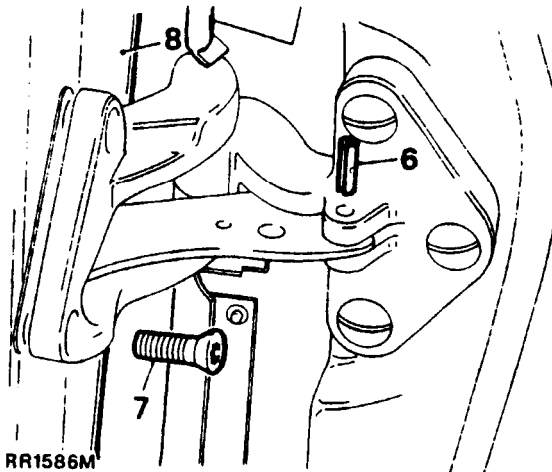

Refitting

9. Refit the door and feed the electrical cables through the 'A' post.
10. Fully open the door and reconnect the electrical leads, take up the slack in the leads and clip them securely to the footwell side panel, refit the convolute grommet to the 'A' post frame.
11. Check the location of the door and the operation of the door lock. If necessary, adjust the door and striker plate.



12. Adjust the door by the addition of shims between the hinge and door or hinge and 'A' post to take the door forward or rearward in the opening.
13. By loosening the six screws securing the hinges to the door, the door can be adjusted up and down or in and out of the opening.

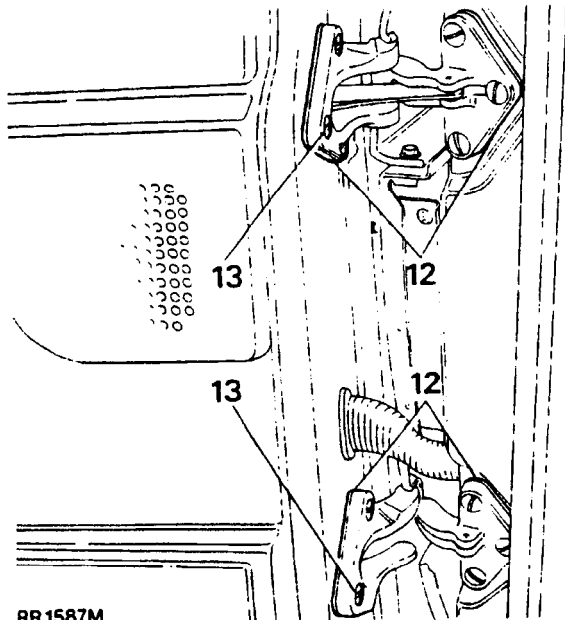

RR1587M

14. The door lock striker can be adjusted by loosening the striker and moving it in the appropriate direction or adding and subtracting spacing washers between the striker and 'B' post.

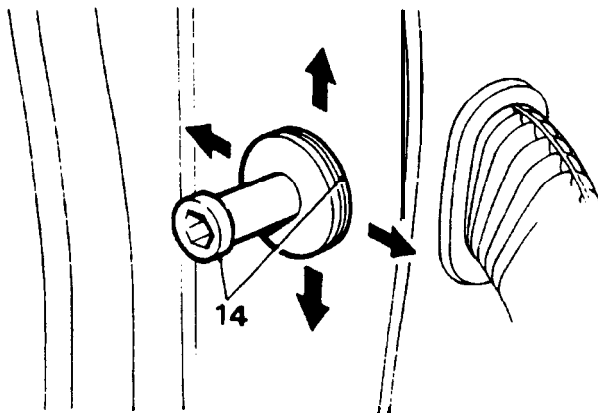

RR1588M

**FRONT DOOR GLASS AND REGULATOR**

Remove and refit

**Removing**

1. Ensure the window is in its fully closed position and secure it with adhesive tape to prevent the window dropping down.
2. Disconnect the battery negative terminal.
3. Detach the armrest/door-pull finisher to reveal the two securing screws.
4. Remove the two securing screws (with plain washers) to enable the armrest/door-pull to be detached from the inner door panel.
5. Remove the interior door handle finisher button to reveal the screw retaining the handle surround.
6. Remove the screw and detach the handle surround from the inner door panel.
7. Detach the inner door trim pad by inserting a screwdriver between the trim pad and inner door panel, gently pry out the nine plastic securing clips from their respective holes in the inner door panel.
8. Disconnect the two speaker connections inside the door and remove the door trim pad complete with speaker.
9. Remove the plastic vapor barrier.
10. Remove the window lift motor (refer to Electrical Section).
- ii. Remove the four window regulator retaining bolts with shakeproof washers from the inner door panel.

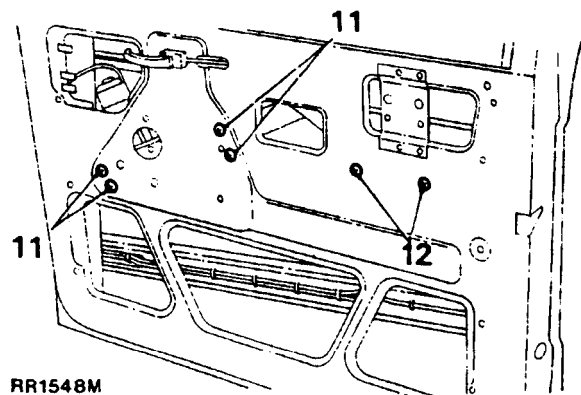

RR1548M

Continued

12. Remove the two screws with shakeproof washers retaining the lower window lift channel and slide the channel off the stud.
13. Disengage the lifting arm stud from the upper lifting channel, maneuver the window regulator and remove it from the lower centre opening in the inner door panel.

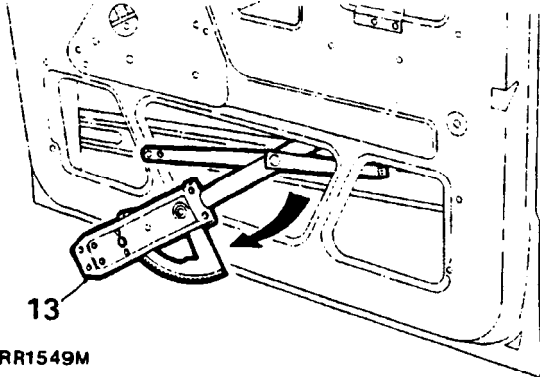

RR1549M

14. Remove the sill locking knob.
15. Remove the inner door capping off its keyhole location.
16. Remove the exterior driving mirror (refer to exterior driving mirrors removal and refit in Electrical Section).
17. Remove the waist rail seal from the top of the door panel.

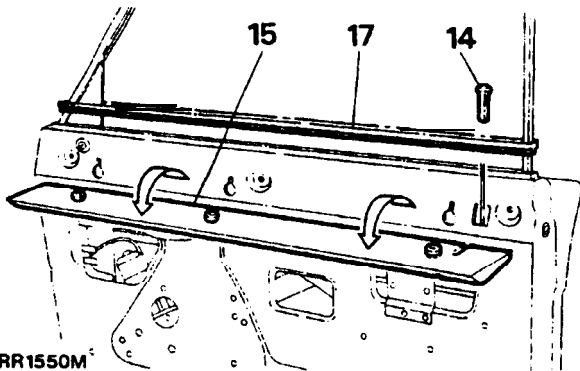

RR1550M

18. Remove the two bolts (shakeproof and plain washers) from the hinge face of the door which secure the front door frame.
19. Remove the single bolt (spring and plain washer) from the edge of the door which secures the door rear frame.

20. Remove the bolt (spring and plain washer) from the recessed hole in the front of the inner door panel under the exterior driving mirror mounting plate.
21. Remove the single screw (spring and plain washer) from inside the door securing the bottom front glass channel.
22. Remove the single screw (spring and plain washer) from inside the door securing the bottom rear glass channel.
23. Lift the door glass frame complete with glass out of the door panel and remove to a suitable bench.
24. Remove the adhesive tape securing the glass to the frame.
25. Slide the glass out of the door frame channel.

#### Refitting

26. Reverse the removal instructions, items 1 to 25.

NOTE: When refitting the door **glass** frame, ensure it is repositioned to suit the door opening before fully tightening the door frame securing bolts.

#### FRONT DOOR LOCK, OUTSIDE AND INSIDE DOOR RELEASE HANDLES

##### Remove and refit

##### Removing

1. Remove the window lift motor (refer to Electrical Section).
2. Remove door glass and regulator (refer to door glass and regulator remove and refit).
3. Remove door actuator units (refer to Electrical Section).
4. Disconnect the control rod from the private key operated lock by releasing the metal clip at the bottom of the rod.
5. Disconnect the control rod from the outside door release handle by pulling it out of the plastic ferrule.

6. Disconnect the control rod connector between the inside door release handle and the door lock by releasing the metal clip and pulling one of the control rods out of the plastic connecting block. This is accessible through the small centre cut-out in the door panel. (The control rod also passes through a guide bracket on the inside of the inner door panel).
7. From inside the door panel push out the small pin which secures the quadrant to the inner door panel. Push the quadrant out of the panel.
8. Release the door lock by removing the two counter-sunk screws from the door edge and the single screw (with shakeproof washer) on the inner door panel.
9. Withdraw the lock through the lower rear cut-out on the inner door panel.

NOTE: If necessary the following items can also be removed.

10. Remove the two nuts (with shakeproof washers) and retaining bracket securing the outside door release handle to the outer door panel, accessible through the upper rear cut-out on the inner door panel.
11. Carefully detach the door release handle from the outer door panel.
12. Remove the two screws securing the inside door release handle to the inner panel.
13. Withdraw the handle from its location with half the connecting rod still attached.
14. Unclip the spring tensioned end of the connecting rod from the door release handle.

Refitting

15. Reverse the removal procedure items 1 to 13.

NOTE: When refitting the door glass frame, ensure that it is positioned to suit the door opening before fully tightening the door frame securing bolts.

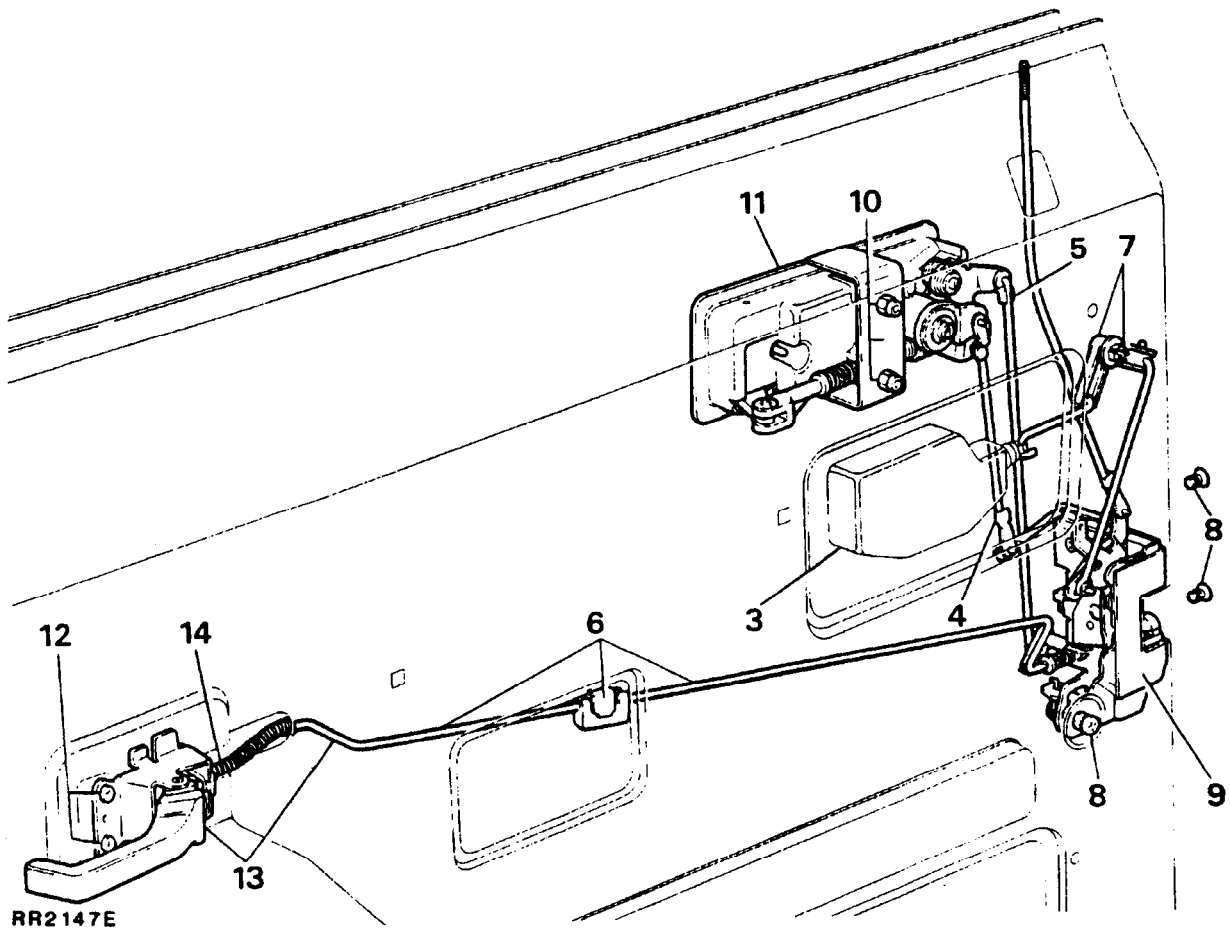

## ADJUSTMENT-FRONT DOOR LOCK AND HANDLE ASSEMBLY

## Inside door release handle to lock

1. Refit the inside door release handle surround before any adjustment is made, allowing the handle to be set from the correct operating position.
2. Rotate the spring tensioned nyloc nut at the opposite end of the interior handle connecting rod, clockwise or counter-clockwise to shorten or extend the operating length.

## Outside door release handle to lock

3. Disconnect the connecting rod at the rear of the outer door release handle by releasing it from the plastic ferrule rotate the rod clockwise or counter-clockwise to shorten or extend the operating length, refit the rod to the ferrule.

**NOTE:** Door release should be effective before the total handle movement is exhausted to provide a small overthrow movement.

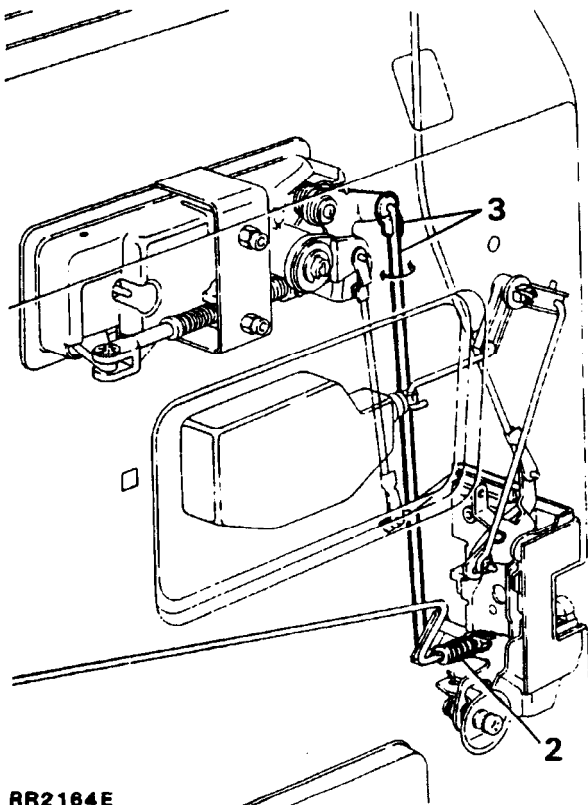

RR2164E

## REAR PASSENGER DOOR

## Remove and refit

## Removing

1. Disconnect the battery negative lead.
2. Pull the convolute grommet out of the face of the 'B' post.
3. Withdraw the electrical leads from the 'B' post until the electrical plugs are exposed and disconnect the plugs.
4. Remove the two bolts (with spring and plain washers) securing the door check strap.
5. Open the door slightly, support the door and remove the six bolts (with spring washers) securing the hinges to the 'B' post.
6. Lift the door clear.

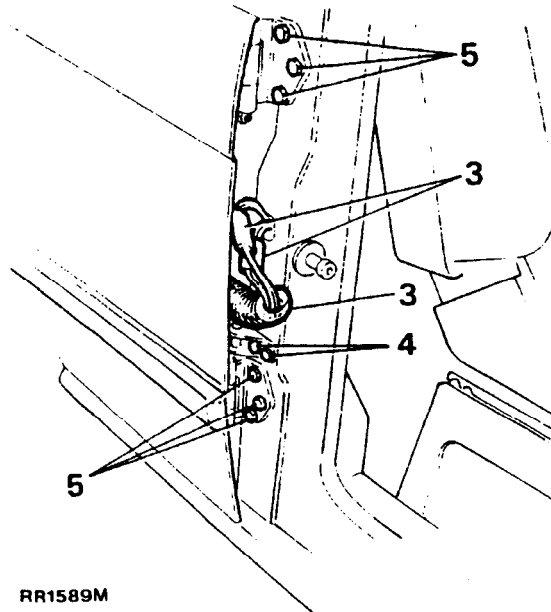

RR1589M

## Refitting

7. Reverse the removal procedure.
8. Adjustment to the rear doors is made by releasing the six hinge securing bolts (hinge to 'B' post) and moving the door either rear-wards, forward, up or down in the door opening.
9. Adjustment to the door striker is identical to front door adjustment.

**REAR DOOR GLASS AND REGULATOR**

**Remove and refit**

**Removing**

Ensure the window is in its fully closed position and secure it with adhesive tape over the top of the door to prevent the window dropping down.

2. Disconnect the battery negative terminal.
3. Remove the armrest/door-pull finisher to reveal the two securing screws.
4. Remove the two securing screws (with plain washers) and detach the armrest/door-pull from the inner door panel.
5. Disconnect the window lift switch multi-plug at the rear of the armrest/door-pull.
6. Remove the interior handle finisher button to reveal the screw retaining the handle surround.
7. Remove the screw and detach the handle surround from the door trim pad.
8. Remove the door trim pad by inserting a screwdriver between the trim pad and the inner door panel, gently pry out the six plastic clips from their respective holes around the edges of the trim.
9. Remove the sill locking button.
10. Remove the inner door capping from its keyhole location.
11. Remove the plastic vapor barrier.
12. Remove the window lift motor (refer to Electrical Section).
13. Remove the four window regulator securing screws (with shakeproof washer).

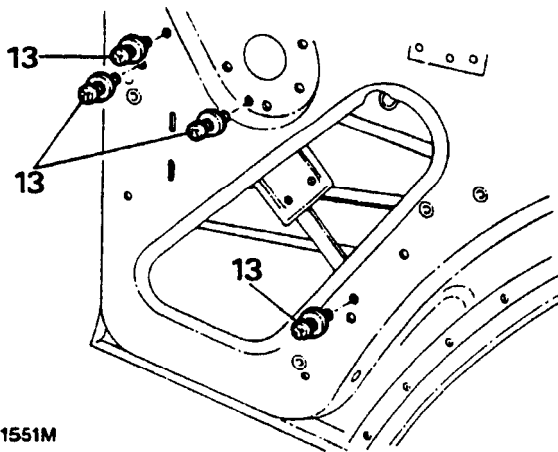

14. Carefully disengage the lifting arm stud from the glass lifting channel and remove the window regulator from the lower opening in the inner door panel.

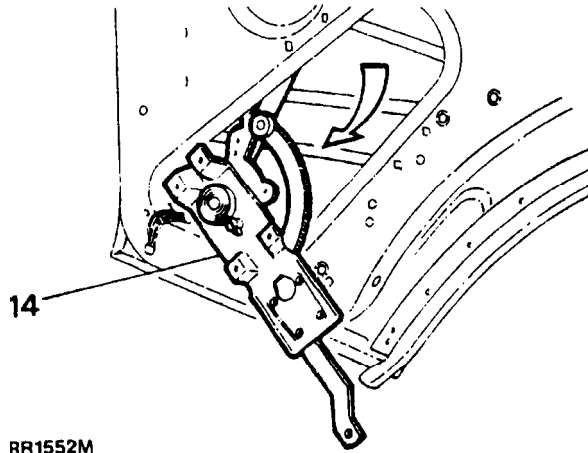

15. Remove the waist rail seal from the top of the door panel.
16. Remove the single bolt (with spring and plain washers) from inside the door which secures the bottom of the short rear glass run channel.
17. Remove the two bolts (with spring and plain washers) from the hinge face of the door.
18. Remove the two bolts (with spring and plain washers) from the edge of the door which secure the rear door frame.
19. Lift out the door frame with the glass in position and remove to a suitable workbench.
20. Remove the tape and slide the glass out of the door frame channel.

**NOTE:** When refitting the door glass frame securing bolts, ensure that the door frame is adjusted to suit the door opening before fully securing the frame to the door.

**Continued**

## REAR DOOR LOCK, OUTSIDE AND INSIDE DOOR RELEASE HANDLES

### Remove and refit

#### Removing

1. Ensure the window is in its fully closed position.
2. Remove all the interior door trim (refer to door glass and regulator remove and refit, items 2 to 11).
3. Disconnect the control rod **from** the inside door release handle by pulling the rod out of its location at the door lock.
4. Disconnect the sill locking control rod from the door lock by releasing the metal clip.
5. Disconnect the control rod from the outside door release handle by pulling it out of the plastic ferrule.
6. Release the door lock by removing the two counter-sunk screws from the door edge and the single screw (with shakeproof washer) on the inside of the door. Retrieve any spacing washers which may be fitted between the inner door panel and the lock.

7. Withdraw the lock through the upper rear opening in the inner door panel.

**NOTE:** If necessary the following items can also be removed.

8. Remove the two nuts (with shakeproof washers) and retaining bracket securing the **outside door release handle** to the outer door panel, accessible through the upper rear cut-out on the inner door panel.
9. Carefully detach the outside door release handle from the outer door panel.
10. Remove the two screws (with plain washers) securing the **inside door release handle** to the inner door panel.
11. Withdraw the handle from its location with the connecting rod still **attached**.
12. Unclip the spring tensioned end of the connecting rod from the door release handle.

Continued

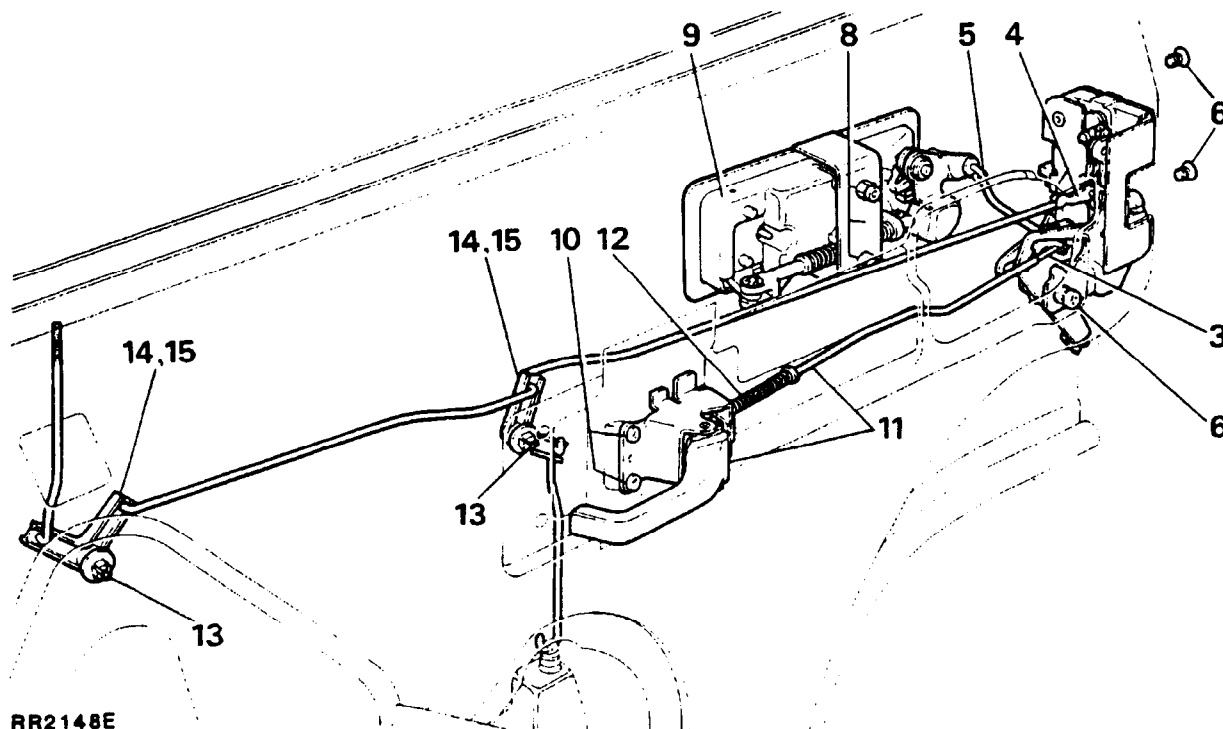

**Sill locking quadrants**

13. Use a small screwdriver, or 3.175mm diameter (1/8 in) rod, press the plastic locking pins through the respective square inserts in the inner door panel, until they can be retrieved from inside the door.
14. Release the quadrants from the inner door panel and unhook the respective connecting rods.
15. Withdraw the quadrant from inside the door.

**NOTE:** When refitting the quadrants the plastic locking pins are entered into the square insert from outside and pressed in flush.

**Refitting**

16. Reverse the removal procedure 1 to 15.

**ADJUSTMENT-REAR DOOR LOCK AND HANDLE ASSEMBLY**

**Outside door release handle to lock.**

1. Disconnect the short offset connecting rod at the rear of the outer door release handle, rotate the rod clockwise or counter-clockwise to shorten or extend the operating length.

**NOTE:** Door release should be effective before the total handle movement is exhausted to provide a small over-throw movement.

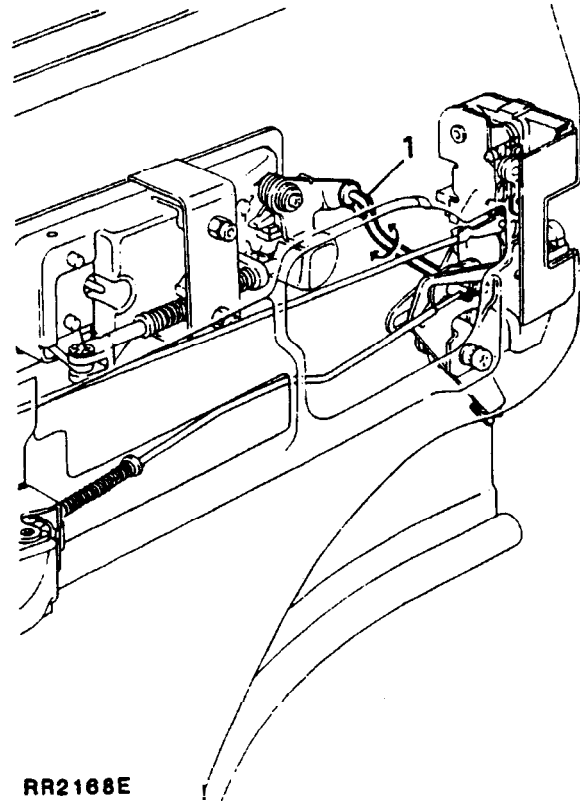

**WINDSCREEN GLASS****Remove and refit****Removing**

**CAUTION:** Place a protective covering over the cowl panel and dashboard to prevent damage to the bodywork and also to prevent broken glass entering the heater system.

1. Remove the windscreen wiper arms.
2. Remove the expander strip from the channel in the rubber moulding around the glass.
3. Remove the rubber moulding from the windscreen opening.
4. Remove any previous sealing compound from around the opening.
5. Thoroughly clean the windscreen opening and remove any broken glass.

**Refitting**

**CAUTION:** To ensure a good bond is achieved between windscreen and rubber DO NOT use petroleum based solvents or liquid soap to clean or aid assembly of the windscreen to rubber.

6. Apply Sikaflex 207 cleaner primer to the windscreen and rubber to remove any oil based film that may be present.
7. Apply Sikaflex 221 or 255 adhesive sealant to the exterior channel of the **NEW** rubber moulding, ensure the sealant is applied to the bottom of the channel.
8. Fit the rubber moulding to the windscreen opening.
9. Ensure that the edge of the 'A' post interior trim panels are fitted under the lip of the rubber moulding.
10. Fit the windscreen into either bottom corner of the rubber moulding channel.

11. Work the glass into the bottom of the windscreen rubber using a soft blunt implement shaped with a wedge type point, working up and around the seal and at the same time pushing the screen onto the rubber, ease the lip of the seal over the windscreen glass as illustrated.

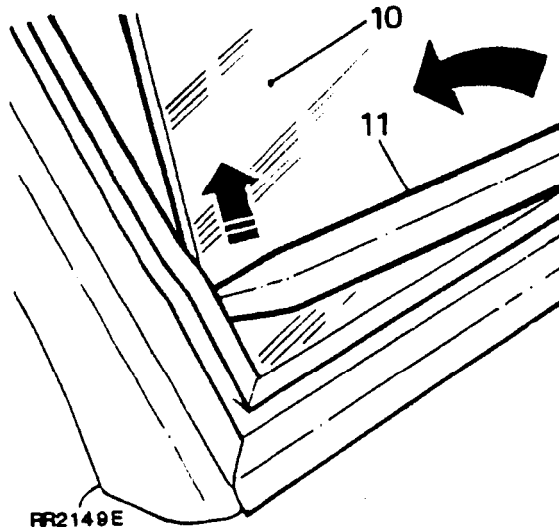

12. Apply Sikaflex 221 or 255 adhesive sealant between the outer lip of the rubber moulding and exterior surface of the windscreen, ensure the sealant is applied to the bottom of the channel.

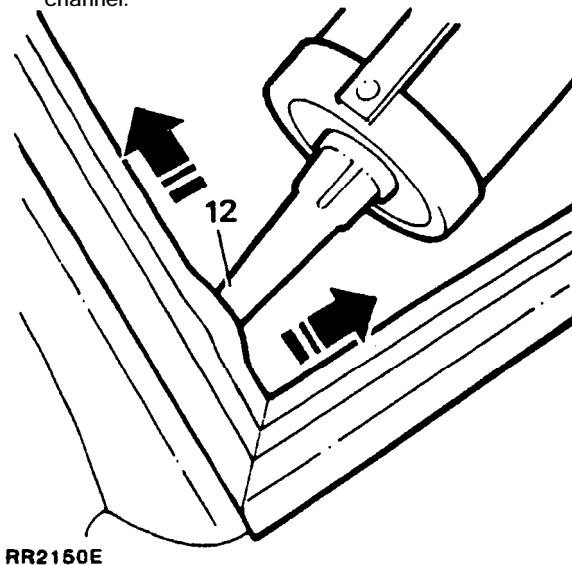

**CAUTION:** To aid assembly of expander strip to the windscreen rubber apply a small amount of soap solution to the channel on the face of the rubber. Ensure that the soap solution is applied to the channel only.

13. To aid insertion apply mineral spirit to the rubber expander strip channel.



14. Fit the expander rubber to the channel, do not overstretch the rubber.
15. If any of the rubber strip protrudes beyond the channel after fitting, trim off at 45° with a sharp knife.

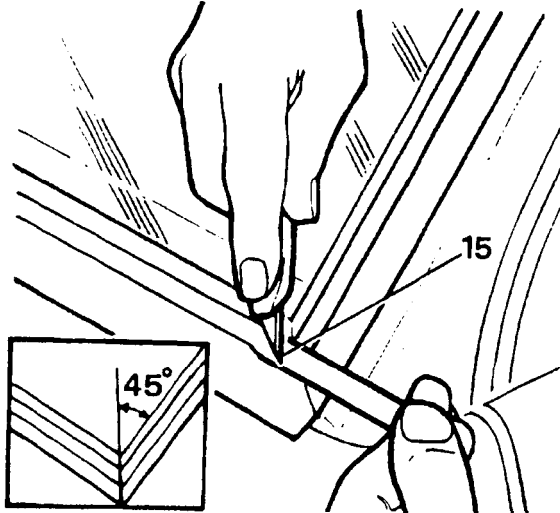

RR2151E

16. Surplus sealant between screen and rubber moulding will be forced out after the expander strip is fitted.
17. Remove the surplus sealant, and wipe away the remaining sealant using Sikadur cleaner.
18. With a blunt instrument lift the bottom of the rubber moulding up and over onto the top of the cowl panel, likewise repeat the operation to bring the bottom of the rubber moulding up and over onto the dashboard.
19. Refit the wiper arms, check the wiper sweep is correct.
20. Reverse the remaining removal instructions.

**TAILGATE GLASS**

**Remove and refit**

**Removing**

1. Remove the upper tailgate.
2. Remove the lock.
3. Remove the lift handle and trim.
4. The upper tailgate glass and frame are serviced as one unit.

**Refitting**

5. Reverse instructions 1 to 3.

**REAR QUARTER LIGHT GLASS**

**Remove and refit**

**Removing**

1. Remove the rubber moulding from around the glass opening.
2. Thoroughly clean the opening to be glazed.

**NOTE:** If a new glass and moulding is being fitted to the driver's side quarter light it will be necessary to remove the spare wheel.

**Refitting**

3. Fit the new moulding to the glass.
4. Fit a draw cord around the exterior surface of the rubber moulding ensuring that it sits securely in the bottom of the moulding retaining channel.
5. Coat the glass opening in the body side with liquid soap to aid assembly.
6. Fit the glass and moulding to the glass opening ensuring that the draw cord is fed into the interior stowage area.

**NOTE:** It may be necessary to remove the seat belt inertia reel and cover.

7. With assistance from a second operator pushing the glass and moulding into the opening pull the draw cord from the moulding enabling the seal to ride up over the bodyside retaining lip.
8. Ensure the interior trim lies under the rubber moulding.

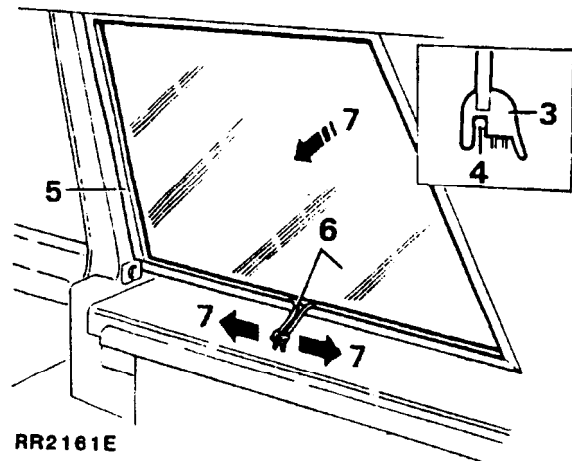

RR2161E

## FRONT SEAT

## Remove and refit

## Removing

1. Remove the single screw securing the seat base side trim panel and withdraw the panel.
2. Remove the three screws securing the seat base front trim panel to the front footwell, remove the single screw securing the top of the front trim panel to the seat base located under the seat base cushion, and withdraw the panel.
3. Remove the three fixings securing the seat cushion side trim panel and withdraw the panel. Remove the bolt securing the seat belt to the side of the seat.
4. Move the seat until it is in its most rearward position.
5. Remove the two fixings securing the front of the seat located in each seat slide channel.

6. Move the seat until it is in its most forward position.
7. Remove the four fixings securing the rear of the seat located inside each seat slide channel.
8. Disconnect the battery negative terminal.
9. Disconnect the electrical multi-plugs to the seat motors and seat control switch.
10. Withdraw the seat from the vehicle.
11. If necessary the seat motors and operating switch can be removed. (Refer to Section 86 Electrical).

## Refitting

12. Reverse the removal instructions.
13. Arrange the electrical leads beneath the seat to ensure that they do not become trapped by the seat slide mechanism.

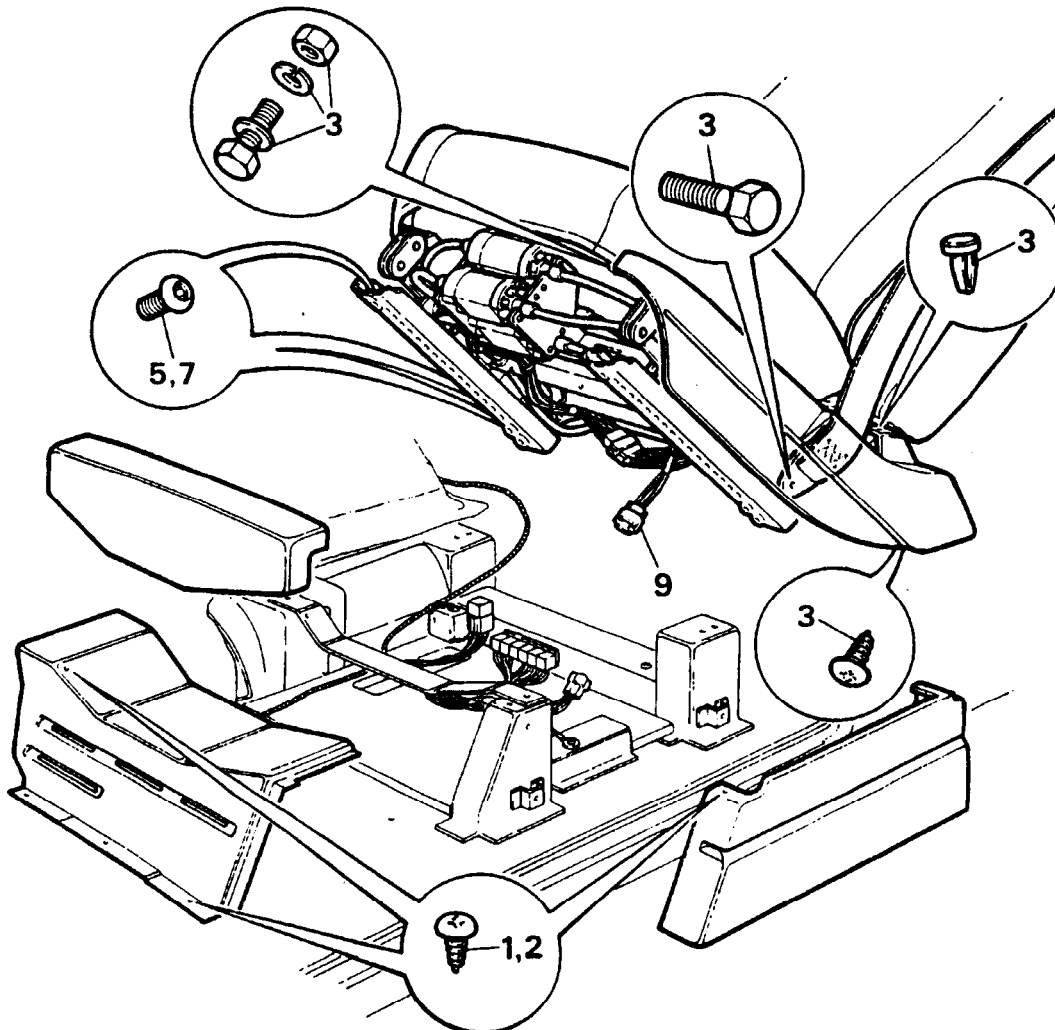

RR2152E

**ASYMMETRIC SPLIT REAR SEAT**

**Remove and refit**

**Removing**

1. Lift the finger button to release the seat back rest securing catch and fold the seat forward.
2. While folding the seat forward feed the rear seat lower part of the seat belt through the opening between the seat back and cushion.

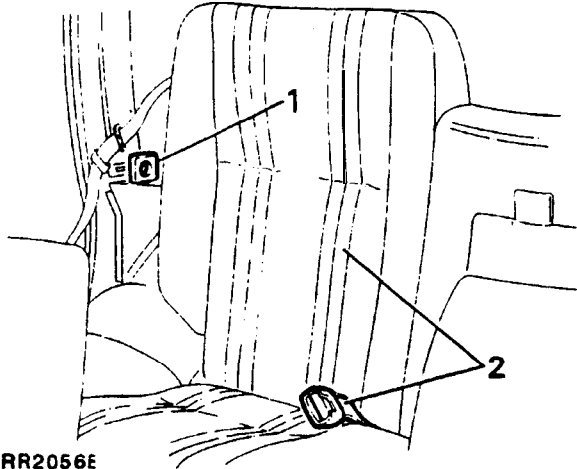

RR2056E

3. Fold the seat fully forward and remove the four rear pivot bracket bolts.
4. Fold the seat back and lift the rear footwell carpet from just below the front of the seat to gain access to the four front fixings securing the pivot brackets, remove the bolts, withdraw the seat assembly from the vehicle.

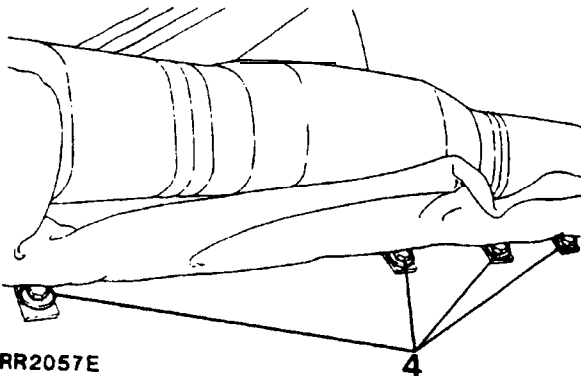

RR2057E

**Refitting**

5. Reverse the removal procedure ensuring that all fixings are securely tightened.
6. Adjust the seat mechanism plate if necessary.

**ASYMMETRIC SPLIT REAR SEAT  
LOCKING MECHANISM**

**Remove and refit**

**Removing**

1. Lift the finger button and fold the seat back rest forward.
2. Remove the spring clip securing the finger button operating rod to the lock mechanism lever, accessible through the lock mounting bracket, withdraw the finger button.

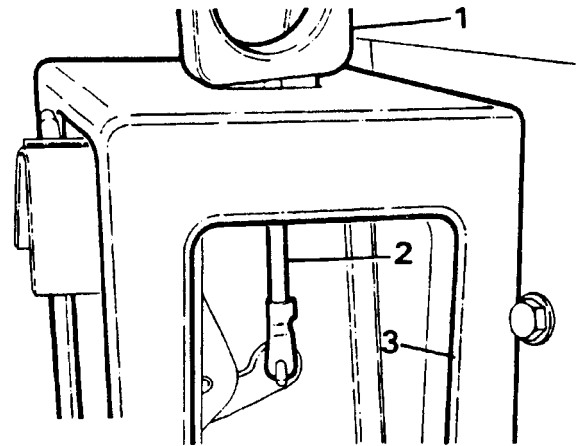

RR2058E

3. Remove the trim stud and remove trim covering.
4. Remove the three screws from the face of the lock catch plate.
5. Maneuver the catch plate off the lock mechanism.
6. Retrieve the lock mechanism from the mounting bracket opening.

**Continued**

ASYMMETRIC SPLIT REAR SEAT  
LOCKING MECHANISM

Adjust

1. Release the finger button and fold the seat back rest forward.
2. Loosen the three screws securing the catch plate to the lock mechanism.
3. Maneuver the lock assembly either horizontally, vertically or diagonally until the catch plate aligns with the striker at the side of the seat.
4. Securely tighten the retaining screws.

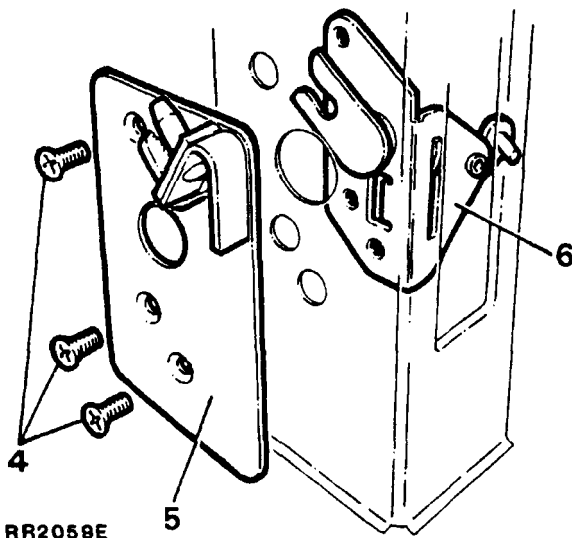

RR2059E

Refitting

7. Lightly grease the internal lock mechanism.
8. Reverse the removal instructions.
9. Adjust the lock catch plate to align with the seat striker.

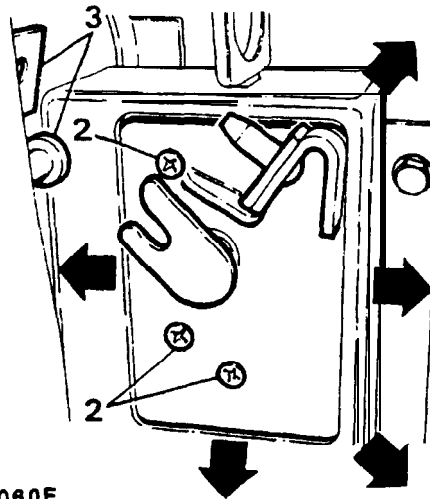

RR2060E

**SEAT BELTS**

**Description**

The seat belt assemblies are factory fitted in the correct location. If removal is necessary the procedures in this section must be followed. All seat belt fixings **MUST** be tightened to the correct torque (see section 06-Torque values).

Seat belt assemblies **MUST** be replaced after they have been subjected to loading by occupants in a collision. Where replacement is necessary, the original manufacturer's components must be used.

An audible warning and warning lamp are incorporated in the system. The warning lamp will illuminate for eight seconds when the ignition is switched on regardless of seat belt usage.

The audible warning will sound with an intermittent high and low note for four to eight seconds unless the driver's seat belt is used.

A single lap belt is provided for the occupant of the centre rear seat.

**REAR SEAT BELT**

**Remove and refit**

**Removing**

1. Detach the plastic cover from the upper seat belt guide bracket and remove the securing bolt, plain and wavy washer and spacer.
2. Remove the clip-on cover from the inertia reel assembly. Remove the securing bolt and spring washer and place the reel to one side.

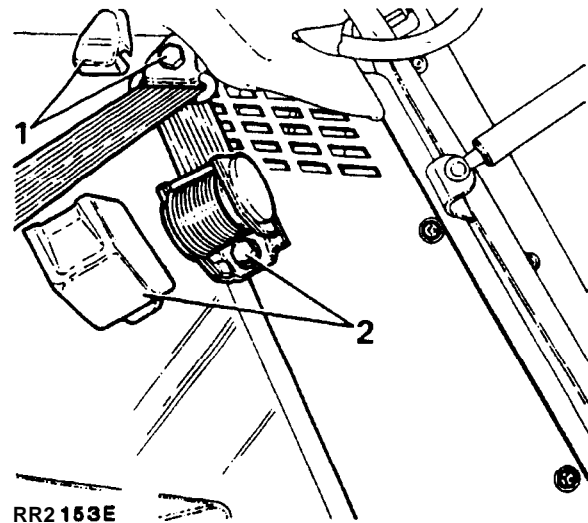

RR2153E

3. Remove the plastic cover and remove the bolt securing the belt to the rear wheel arch.

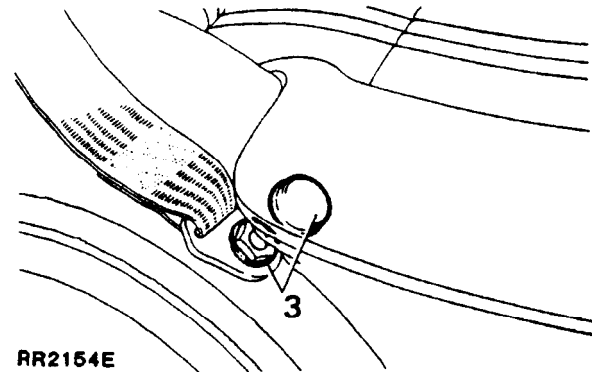

RR2154E

4. Withdraw the assembly.

Continued

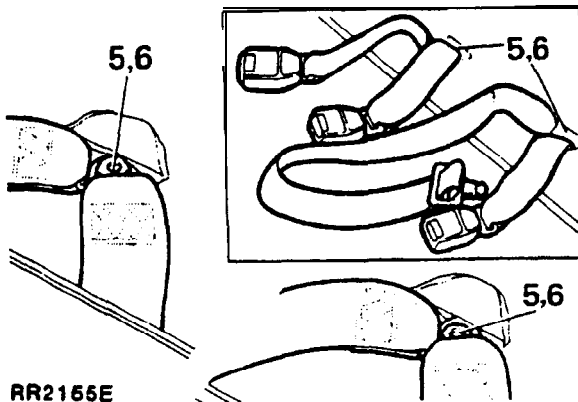

RR2155E

5. Working behind the rear seats, remove the bolt and plain washer and withdraw the buckle assembly.
6. Centre lap strap only: working behind the rear seats, remove the bolts securing the lap strap and the buckle assembly and withdraw both components.

#### Refitting

7. Reverse the removal procedure ensuring that the harnesses are not twisted. Finally tighten the fixings to the correct torque (see section 06-Torque values).

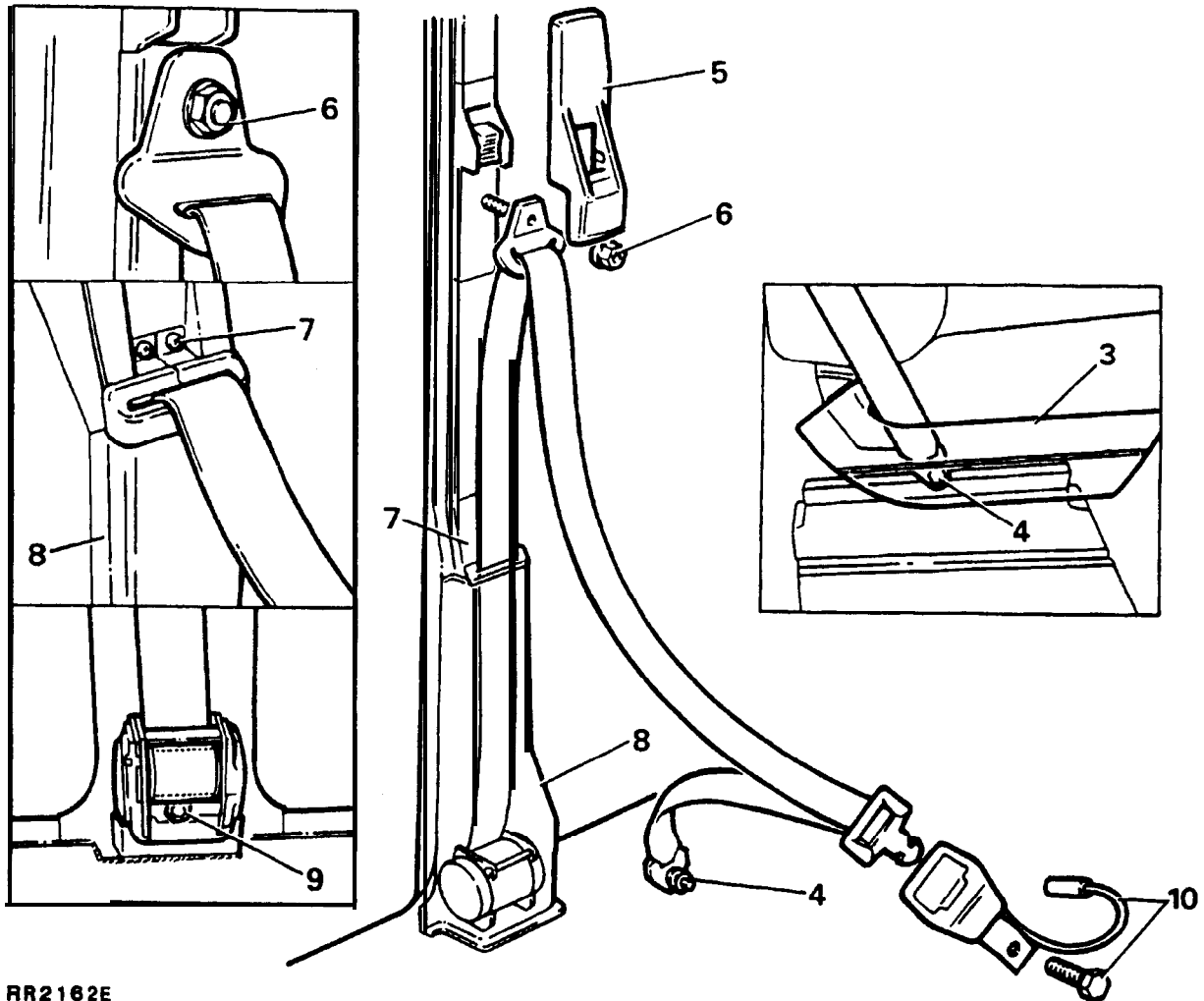

RR2162E

**FRONT SEAT BELT**

**Remove and refit**

**Removing**

1. Adjust the front seat to the mid-position.
2. Disconnect the battery negative lead.
3. Remove the seat cushion side trim panel - see Front Seat - remove and refit, page 34, Section 76.
4. Remove the bolt, plain washer and spacer securing the belt to the seat base.
5. Remove the moulding from the adjustable seat belt mounting.
6. Remove the shouldered nut and spacer securing the seat belt to the 'B' post.
7. Remove the two screws securing the trim finisher and release the finisher from the belt.
8. Ease the door seal away and remove the lower 'B' post trim casing.
9. Remove the bolt and spring washer securing the inertia reel assembly to the 'B' post and withdraw the assembly.

10. Disconnect the electrical connection and remove the bolt securing the buckle to the seat base.

**Refitting**

1. Reverse the removal procedure ensuring that the belt is not twisted. Finally tighten the fixings to the correct torque (see section 06-Torque values).

## FRONT DOOR STOWAGE BINS

## Remove and refit

## Removing

1. Remove the seven fixings securing the stowage bin to the inner door trim pad.
2. Withdraw the stowage bin.

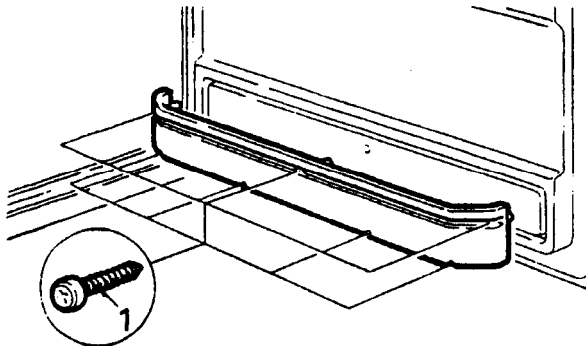

RR2054E

## Refitting

3. Reverse the removal procedure.

## GLOVE BOX AND FLOOR MOUNTED CONSOLE ASSEMBLY

## Remove and refit

## Removing

1. Disconnect the battery negative lead.
2. Remove the four cross-head screws securing the glove box liner to the glove box and withdraw the liner.
3. Disconnect the electrical leads to the rear passenger cigar lighter.
4. Maneuver the switch panel through the panel opening and place inside the glove box.

**NOTE:** To enable the glove box/ console assembly to be removed, disconnect the parking, brake cable from the parking brake lever, to allow the lever to be raised to its uppermost position.

5. Unscrew and remove the transfer gear knob.

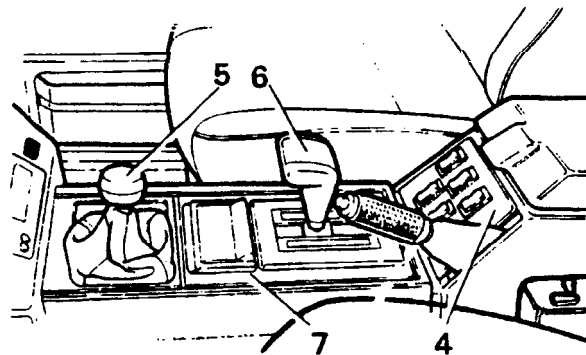

RR2170E

**NOTE:** Refer to Section 86 **Electrical-Automatic gear selector illumination panel**, for full instructions on dismantling the main gear selector knob and illumination panel.

6. Remove the main gear selector knob.
7. Carefully pry the outer inset panel out of the floor mounted console, disconnect the electrical multi-plug to the inset graphics panel, withdraw the assembly off the main gearbox selector.
8. Remove the two bolts (with plain and spring washers) and two screws (with plain washers) securing the floor-mounted console to the gearbox tunnel.



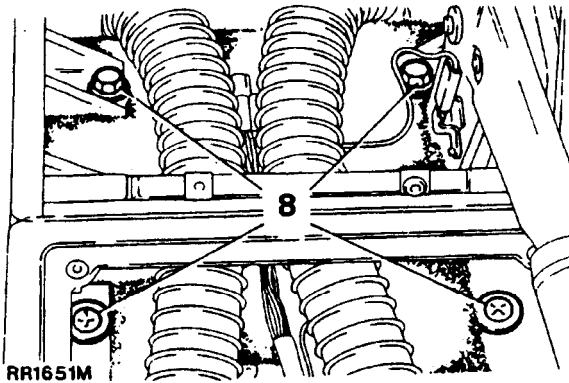

9. Ease the assembly rear-wards to detach the small location tab at the front of the console from the bottom of the radio housing.
10. Maneuver the assembly from the parking brake and gear levers and remove it from the vehicle.

**Refitting**

11. Reverse the removal procedure ensuring that all electrical plugs are fitted securely and correctly. Arrange the electrical wiring beneath the console to ensure it does not become trapped between any joint faces.

**LOWER DASH PANEL**

**Remove and refit**

**Removing**

1. Disconnect the battery negative lead.
2. Pry the louvre from the dash.
3. Remove the two cross-head screws from the bottom of the panel located above the pedals.
4. Remove the single cross-head screw from the side of the panel adjacent to the front door courtesy light switch.
5. Remove the two cross-head screws from the top of the louvre opening.
6. Remove the single cross-head screw above the rheostat switch.

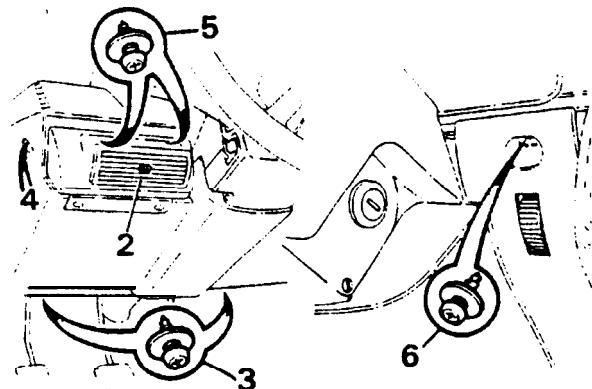

7. Lower the dash panel and disconnect the electrical plug at the rear of the rheostat switch and detach the bulb check unit from the spring clip.
8. Remove the panel from the vehicle.

**Refitting**

9. Reverse the removal procedure.

**RADIO HOUSING**

Remove and refit

Removing

1. Disconnect the battery negative lead.
2. Remove the glove box and floor-mounted console assembly.
3. Remove the radio from the housing (See Manufacturers instructions for removal and installation).
4. Pry the differential lock warning lamp out of the radio console and disconnect the electrical leads.
5. Remove the single screw securing the housing to the gearbox tunnel.
6. Tilt the front of the housing upwards and maneuver it away from the centre dash unit as far as the cigar lighter electrical leads will permit.
7. Disconnect the leads from the rear of the cigar lighter and remove radio housing complete with lighter unit.

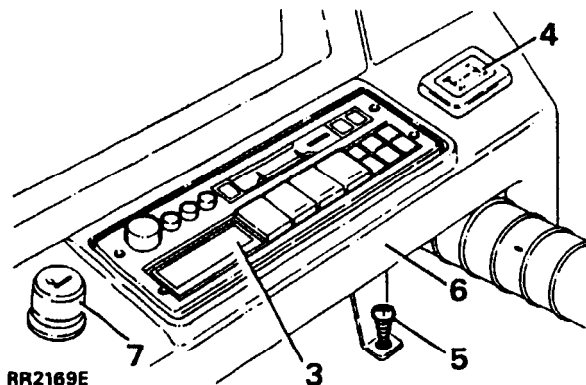

Refitting

8. Reverse the removal procedure ensuring the radio electrical leads do not become trapped when refitting the radio to the housing.

**CENTRE DASH PANEL**

Remove and refit

Removing

1. Disconnect the battery negative lead.
2. Remove the lower dash panel to give access to the single screw securing the side of the centre dash and release the screw.
3. Remove the glove box and floor-mounted console assembly.
4. Remove the radio and radio housing.
5. Detach the fuse box cover and remove the three screws securing the main and auxiliary fuse box body to the dash.
6. Pull the five heater control knobs off their levers.
7. Remove the two screws at the top of the heater graphics panel. Pull the panel away from the dash and remove the illumination bulbs from their locations.
8. Withdraw the graphics panel.
9. Pry the auxiliary switch panel away from the dash.
10. Identify each switch multi-plug to aid reassembly, and disconnect them from the switches.
11. Release the three screws securing the top of the centre dash to the louvre dash panel.
12. Remove the two screws securing the side of the centre dash unit (front passenger side).

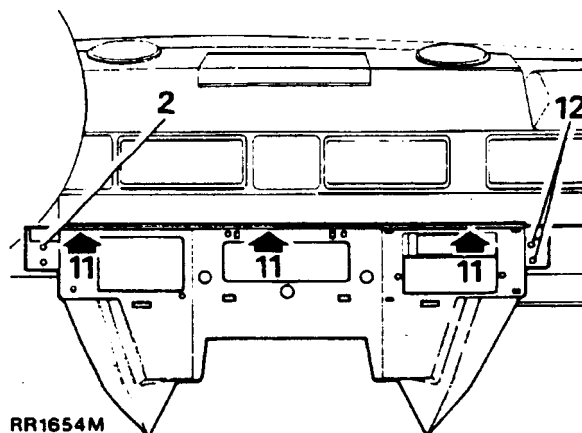

13. Maneuver the centre dash away from the louvre dash and remove it from the vehicle.

**Refitting**

14. Reverse the removal procedure ensuring that all electrical multi-plugs are fitted correctly and secure in their respective switches.
15. Arrange all electrical wiring and harnesses so that they do not become trapped between any mating faces.

**LOUVRE DASH PANEL**

**Remove and refit**

**Removing**

1. Disconnect the battery negative lead.
2. Carefully pry the clock out of the dash, disconnect the electrical leads and remove the bulb and holder from its location.
3. Remove the single screw securing the end of the dash panel located adjacent to the passenger courtesy light switch.
4. Carefully pry the four louvres out of their openings to gain access to the eight screws securing the louvre panel to the dashboard.
5. Carefully pry the exterior mirror control switch out of the louvre panel and disconnect the electrical multi-plugs, remove the remaining screw at the top of the exterior driving mirror control panel opening.
6. Remove the three screws securing the bottom of the panel to the centre dash panel. Remove the remaining three screws above the blower motor trim panel.

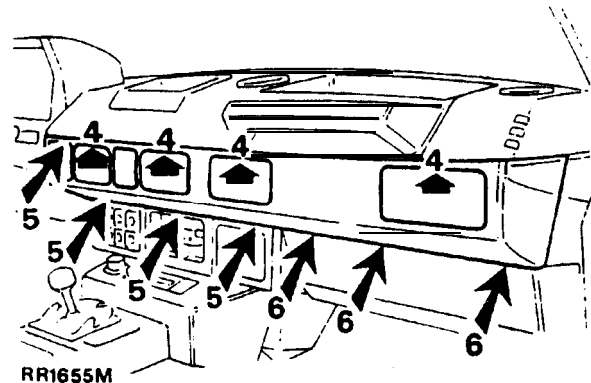

7. Withdraw the louvre panel from the vehicle.

**Refitting**

8. Reverse the removal procedure.

## DASHBOARD

## Remove and refit

## Removing

## Service tools:

**18G1014** • Extractor for steering wheel**18G1014-2** • Adaptor pins

1. Disconnect the battery negative lead.
2. Using service tool 18G1014 and 18G1014-2 remove the steering wheel, secure the cruise control cassette in position with adhesive tape.
3. Remove the lower dash panel from below the steering column.
4. Remove the instrument binnacle (refer to instrument binnacle remove and refit in Section 86-Electrical).
5. Remove the glove box console assembly.
6. Remove the radio housing.
7. Remove the centre dash panel.
8. Detach the dashboard evaporator assembly, do not evacuate the air conditioning assembly, with refrigerant hoses still attached ease the assembly away from the bulkhead and lay on the gearbox tunnel/passenger footwell area. (Refer to Section 82 • Air Conditioning for the removal of the dashboard assembly).
9. Remove the three nuts with washers retaining the front passenger grab handle, accessible from under the dashboard and withdraw the grab handle.
10. Remove the five nuts with washers retaining the map tray base plate, accessible from under the dashboard and withdraw the base plate from the inset in the dashboard.
11. Disconnect the side and centre air vent hoses from the heater unit.
12. Maneuver the dashboard and withdraw it from the vehicle.

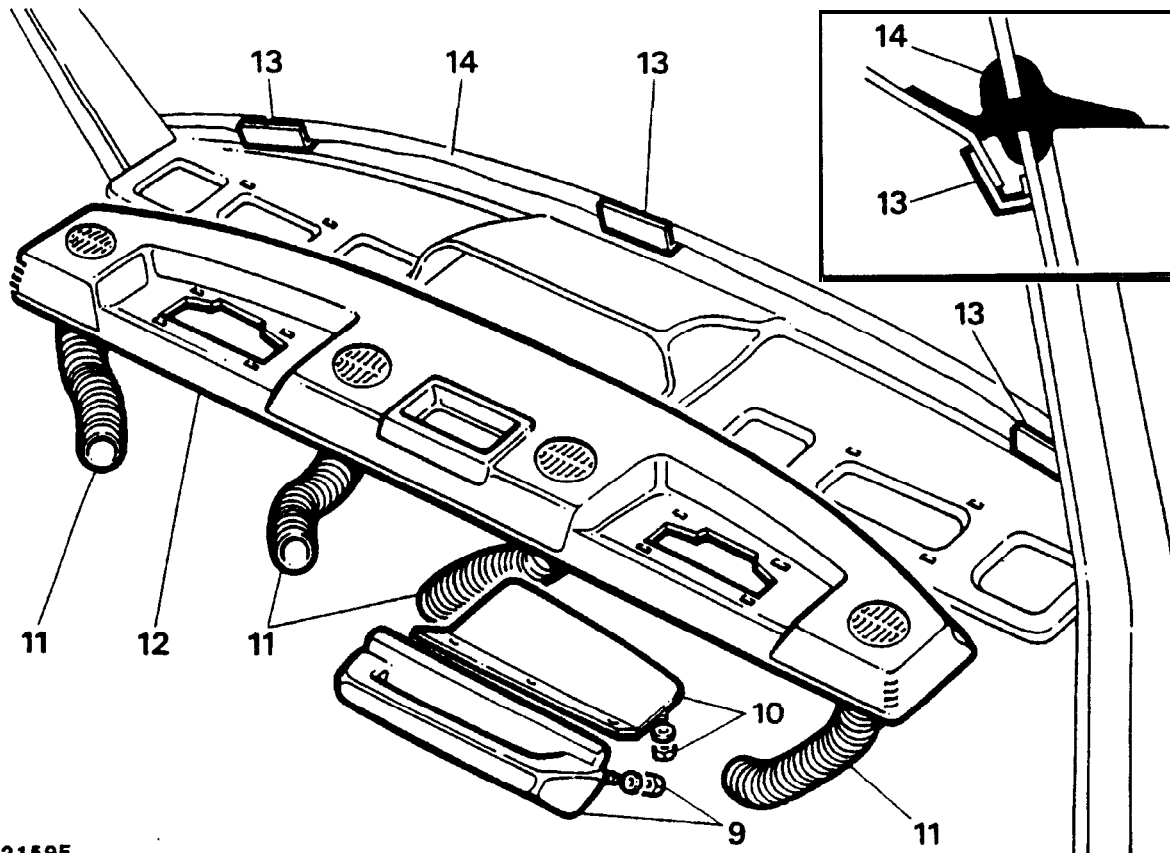

RR2159E

**Refitting**

**CAUTION:** When refitting the dash components ensure that all electrical leads are arranged in such a manner as to prevent them becoming trapped between any of the dash mating faces.

13. Reverse the removal procedure ensuring that the dashboard locates on three brackets below the windscreen inner sealing rubber.
14. Ease the sealing rubber over the top of the dashboard.

**FRONT SPOILER**

The spoiler will reduce the vehicle approach angle by approximately 10". Where the vehicle is expected to perform on rough or hilly terrain, it is advisable to remove the spoiler to prevent any damage which may occur due to ground contact.

The spoiler may be removed as follows:

1. Disconnect the electrical connections at the rear of both auxiliary driving lamps, accessible through the front wheel arches.
2. Remove the two screws (with spring washers) securing the centre of the spoiler.
3. Remove the four nuts (with spring washers) located behind the front bumper above the driving lamp pockets, accessible from beneath the vehicle.
4. Remove the two bolts, nuts and washers securing the outer edges of the spoiler to the corners of the front fenders, located forward of the front road wheels.
5. Remove the spoiler complete with driving lamps.

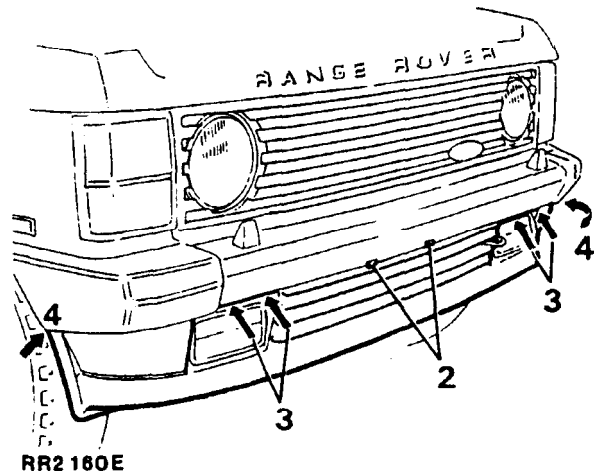

**Refitting**

6. Reverse the removal instructions.

**ELECTRICALLY OPERATED SUNSHINE ROOF**

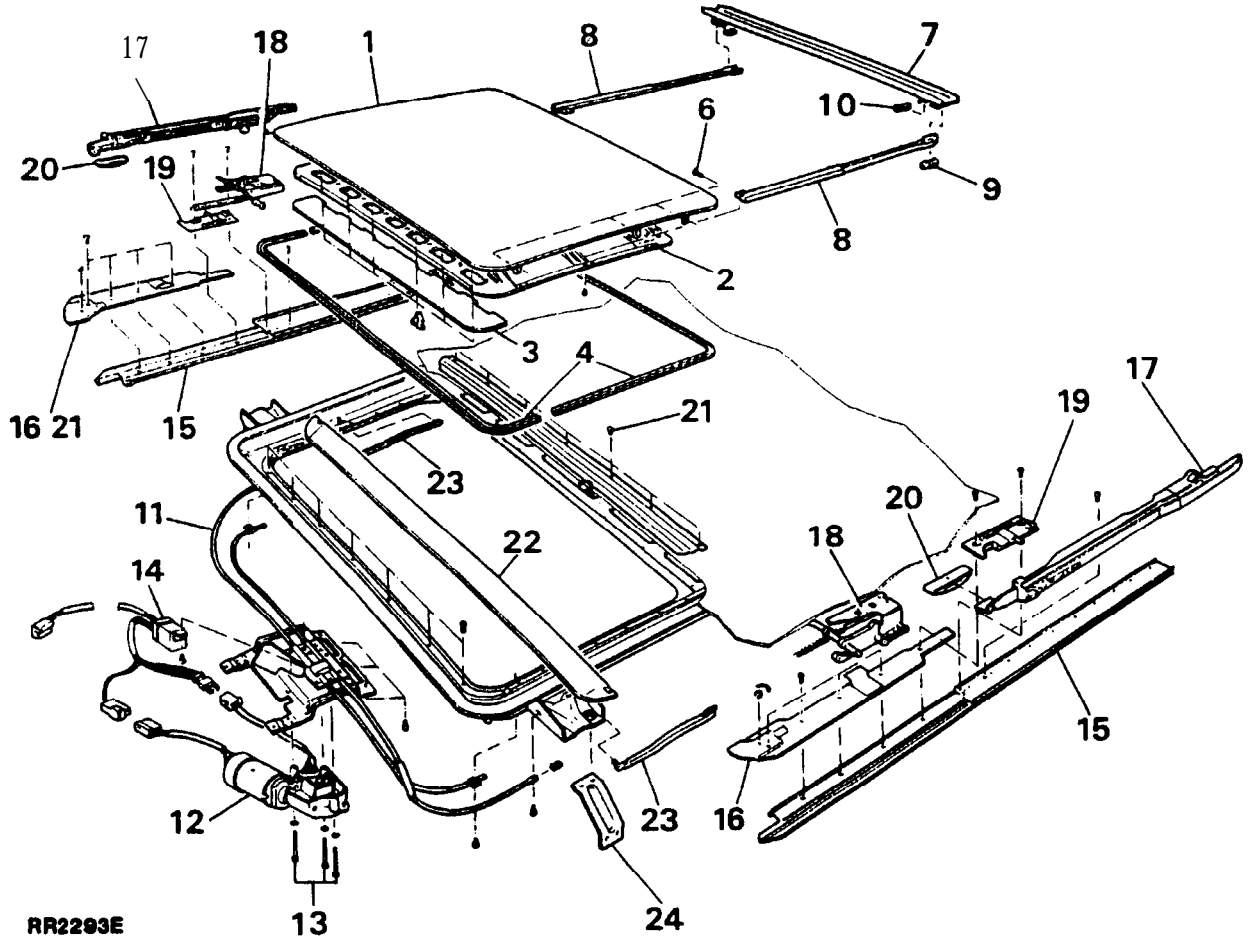

**RR2293E**

**SUNROOF ASSEMBLY**

- |   |                                    |
|---|------------------------------------|
| 1. Roof panel                                       | 13. Motor retaining screws         |
| 2. Sunroof headliner                                | 14. Relay                          |
| 3. Insulation pad                                   | 15. tower guide rails              |
| 4. Roof seals (front and rear)                      | 16. Front guide rails              |
| 5. Sunroof headliner retaining clips (quantity - 6) | 17. Slide mechanism                |
| 6. Roof panel retaining screws (quantity - 6)       | 18. Rear guide                     |
| 7. Water channel                                    | 19. Pivot bracket                  |
| 8. Water channel connectors                         | 20. Slide shoe                     |
| 9. Support bracket-water channel                    | 21. Rear edge trim finisher        |
| 10. Slide shoe-water channel                        | 22. Wind deflector assembly        |
| 11. Motor bracket/guide tube assembly               | 23. Wind deflector operating arms  |
| 12. Operating motor                                 | 24. Support bracket (quantity - 6) |

## OPERATION

The sunroof operates in a tilt and slide action controlled by the rocker switch adjacent to the interior roof lamp, with ignition switched 'ON'.

1. Depress front of switch to lift rear edge of sunroof into 'Tilt' position.
2. Depress rear edge of switch to close roof.
3. Depress rear of switch to slide sunroof into 'Open' position.
4. Depress front of switch to slide sunroof into 'Close' position.

**NOTE: The electric drive cuts out automatically in the closed, tilt and open positions. If the switch is operated in the wrong direction in one of these positions, press the switch once to reset and again to operate roof.**

## EMERGENCY OPERATION

if the sun roof fails to operate, check the fuse and renew if necessary. To close the roof in the event of electrical failure carry out the following procedure.

1. Lower the interior lamp mounting panel by releasing two turnbuckles.
2. Remove the emergency handle from the vehicle tool kit.
3. Engage handle in motor drive spindle and turn to close roof.

## MAINTENANCE

At each service blow drain tubes out to ensure they are not blocked or kinked. Blow upwards to clear rear drain tubes which are clipped to the rear mud flap supports. Blow downwards to clear front drain tubes which run down each 'A' post and exit at back of engine bay.

Annually: Clean sunroof opening thoroughly.

**Note: Where the vehicle is operated in extremely dusty conditions more frequent cleaning is recommended.**

## OPERATING MOTOR, MICRO-SWITCH AND RELAY

**NOTE: The motor drive spindle retaining nut is factory set to the correct torque value. If the roof fails to operate, and drive failure is suspected, check the retaining nut torque and retighten to the correct value - 37 to 44 in lb (4.15 to 5.00 Nm).**

### Remove and refit

#### Removing

1. Ensure sunroof is fully closed. Disconnect the battery negative lead.
2. Remove interior lamp mounting panel by loosening two turnbuckles to gain access to the motor.
3. Disconnect two wiring connectors.
4. Remove three securing screws and withdraw motor.
5. Remove securing screw and withdraw relay.
6. Remove micro-switch from motor by drilling out securing rivets, if required.

#### Refitting

7. Secure new micro-switch using suitable nuts and bolts to replace rivets. Tighten nuts and apply a spot of paint to threads.
8. Ensure motor is in the 'park' position, i.e. hole on driven gear aligned with drive spindle.
9. Reverse removal procedure.
10. Check operation of sunroof in all positions.

## ROOF PANEL SEALS

### Remove and refit

#### Removing

1. Position sunroof in the tilt position and disconnect battery negative terminal.
3. Unclip sunroof headliner from roof panel front and slide the sunroof headliner back fully.
3. Remove three roof panel fixing screws from each side and remove panel.
4. Place the roof panel on a suitable surface to avoid damage, and remove both seals.

Continued

**Refitting**

5. Position front seal to front edge of panel, ensuring that there is an equal length of seal each side of the centre point. Secure seal using a rubber mallet.
6. Position the rear seal on one side immediately to rear of the front seal. Secure seal around panel edge ensuring a good fit around corners. Trim off excess seal at joint with front seal using suitable snips, ensuring that the joint is closed.
7. Refit the roof panel.

**SUNROOF ASSEMBLY****Remove and refit**

- including roof panel, sliding mechanism, wind deflector, motor- mounting bracket and guide tubes.

**Removing**

**NOTE:** lower vehicle headlining **ONLY** if removing motor mounting bracket and guide tubes. Note that the headlining is secured around the roof opening using an adhesive tape. Remove edge trim and eight edge clips, carefully peel back headlining to remove.

1. Partially open sunroof rearwards and carefully unclip sunroof headliner from roof panel front. Slide the sunroof headliner back fully.
2. Position sunroof in the tilt position and disconnect battery negative terminal.
3. Remove three roof panel fixing screws from each side and remove panel.
4. Remove motor securing screws and withdraw motor.
5. Remove the guide rail screws, seven each side.
6. Remove the pivot bracket and remove front guide rail.

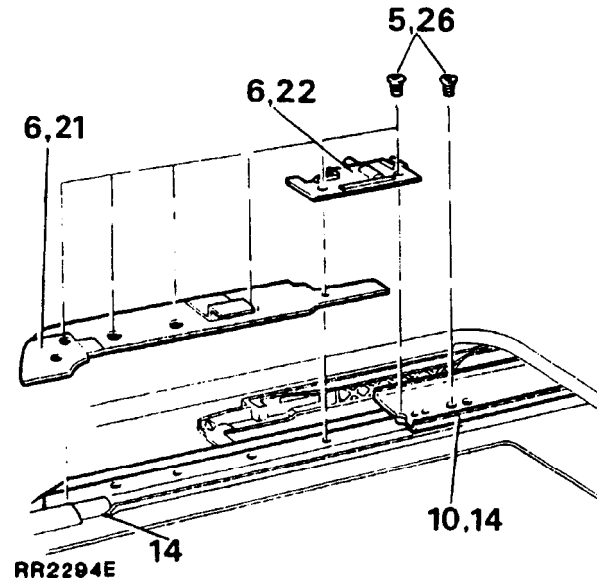

7. Remove the slide and tilt mechanism complete with flexible drive cable from both sides. Do not strip these assemblies unless replacement parts are required.

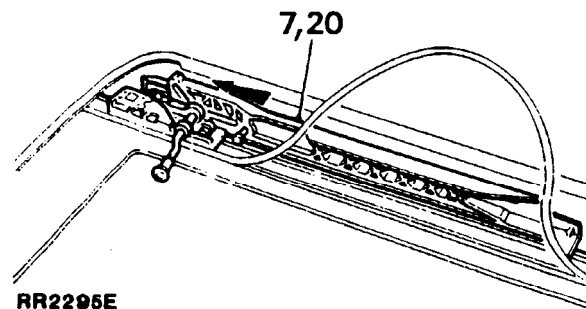

Continued



8. Unclip both wind deflector operating arms from rear mounting brackets. Remove arms from deflector, if required.

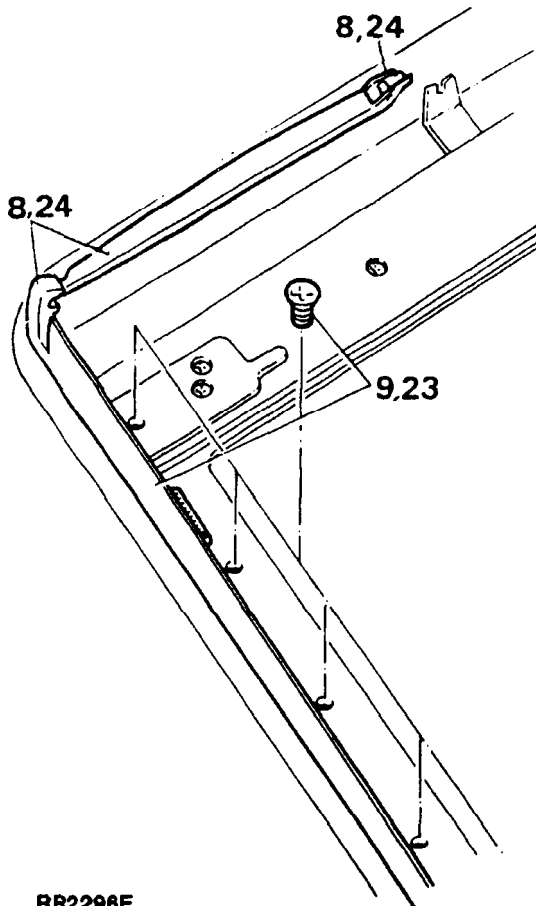

RR2296E

9. Remove seven fixing screws, and withdraw wind deflector.
10. Remove lower guide rails and rear edge finisher, seven screws, if required.
11. Remove fixing screws from guide tubes, two each side. Remove five fixing screws and withdraw motor mounting bracket.
12. Pull sunroof headliner assembly forward and remove.

### Refitting

**NOTE:** During assembly lightly lubricate all sliding parts using a silicon spray.

13. Position motor bracket and guide tube assembly. Fit and tighten the securing screws.
14. Position right hand guide rail in rear retaining bracket, push rearwards fully and locate leading edge under drive cable opening. Repeat operation for left hand guide rail.
15. Align fixing holes, and loosely fit screw in seventh hole from the front.
16. Position finisher to rear edge of sun roof opening and secure using seven screws.
17. Position sunroof headliner assembly into outer guide runners, and push fully rearwards.
18. Lightly lubricate drive cables. Ensure that the slide and tilt mechanism is fully assembled.
19. Push the cable fully into the right hand side guide tube. Loop remaining cable and enter the rear end into the right hand inner side runner.
20. Repeat operation 19. for left hand side. Push both assemblies rear-wards to take up slack in the cables, and push a further 75 mm (3 in) to the rear.
21. Position both front guide rails, aligning with the four forward holes. Secure with screws, do not tighten.
22. Position both pivot brackets, fit but do not tighten fixing screws.
23. Fit the wind deflector and fully tighten fixings.
24. Position right hand operating arm in locating slot in deflector. Secure opposite end in frame bracket. Repeat for left hand side.

**Continued**

25. Pull right hand slide and tilt mechanism forward, align with pivot bracket and secure in position using setting key. Repeat operation for left hand side.

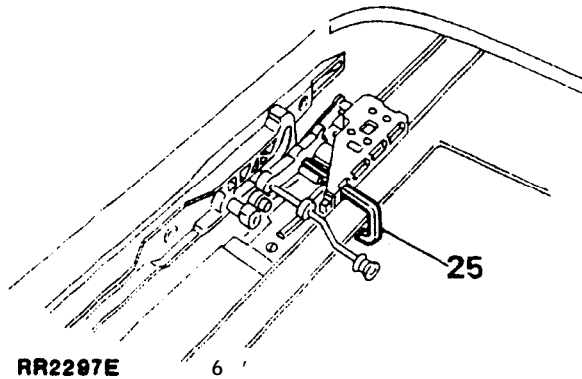

26. Tighten screws to guide rails, seven each side.  
 27. Fit and secure relay.  
 28. Ensure operating motor is in the park position i.e. hole on driven gear aligned with drive spindle. Fit and secure to mounting bracket.  
 29. Remove setting keys. Temporarily connect operating switch and reconnect wiring including battery.  
 30. Operate switch sequence to 'tilt' position.  
 31. Position roof panel into roof opening and secure with six fixing screws, do not tighten.  
 32. Put roof into 'closed' position and adjust roof profile. The panel profile should be 0.5 mm low at forward edge, 1 mm high at rear edge.  
 33. Tighten roof panel screws.  
 34. Tilt sunroof, pull sunroof headliner forward and locate rear brackets in tilt mechanism. Align front six clips and push to secure.  
 35. Check operation of sunroof in all operating modes.

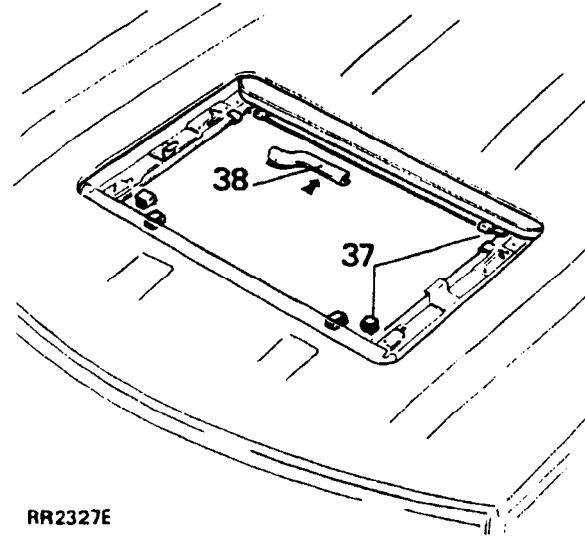

36. Refit vehicle headlining. The headlining is secured around the sunroof opening with '3M' adhesive tape.  
 37. Refit the eight edge clips as shown.  
 38. Finally fit the edging finisher.

**SUNROOF HEADLINER ASSEMBLY**

Remove, retrim and refit

**Removing and retrimming**

1. Remove sunroof headliner assembly as detailed in Sunroof Assembly - remove and refit.
2. Remove trim covering from frame assembly. Note that it is not normally necessary to remove the three pads and insulation pad shown in illustration.
3. If required: remove water channel by unclipping connecting arms. Drill out rivets securing connecting arms to frame.

4. Secure connecting arms to frame using suitable rivets before retrimming frame.
5. Retrim frame using a new headliner cover. inset shows section through frame indicating where adhesive is applied. Dimension 'A' should be radially constant.

**Refitting**

6. Refit sunroof headliner assembly and reassemble sunroof.

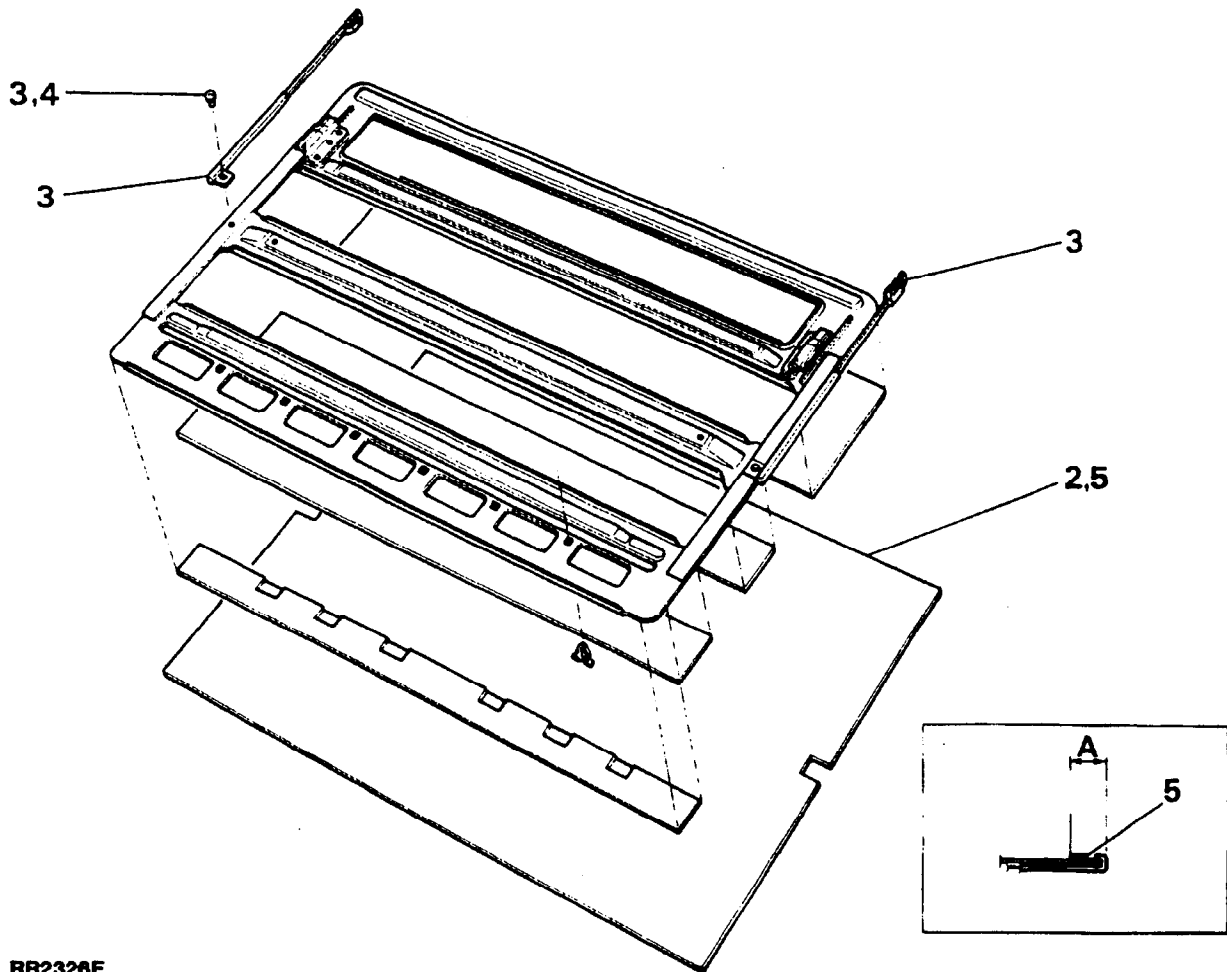

RR2326E

Continued

**HEADLINING - 1987 MODEL YEAR IMPROVEMENT****Remove and refit****Removing**

1. Remove spare wheel from the vehicle.
2. Remove the rear seat belt upper guide brackets and inertia reel assemblies.
3. Fold the rear seat backrest forward and recline the front seats as far as possible.
4. Disconnect the battery negative lead.
5. Remove the two roof lamp assemblies. (Lower and remove the interior lamp mounting panel if the vehicle has a sunroof)
6. Remove the rear view mirror and mounting bracket.
7. Remove the two sun visors and centre retaining bracket.
8. Remove the front and rear passenger grab handles. Sunroof vehicles: Remove edge trim and eight edge clips from roof opening, and carefully peel back headlining to remove.
9. With assistance support the front of the headlining, while removing the two plastic retaining clips above the rear quarter light glass.
10. While the headlining is still being supported, remove the two plastic retaining clips securing the rear end of the headlining, located adjacent to the upper tailgate hinges.
11. Pull the headlining forward to clear the rear quarter trim. Lower the headlining and disconnect the electrical leads from the roof mounted speakers.
12. Remove the headlining through the tailgate.

**CAUTION:** To assist removal tilt the headlining at an angle. DO NOT flex the headlining as damage may occur.

**Refitting**

8. Reverse the removal procedure. Sunroof vehicles: The headlining is secured around the roof opening with '3M' adhesive tape. Refit the eight edge clips and fit the edging finisher. See also Sunroof assembly, remove and refit.

FRONT DOOR • TRIM PANEL

Remove and refit

Removing

1. Disconnect the battery negative terminal.
2. Remove the screw securing the handle surround.
3. Remove the surround.

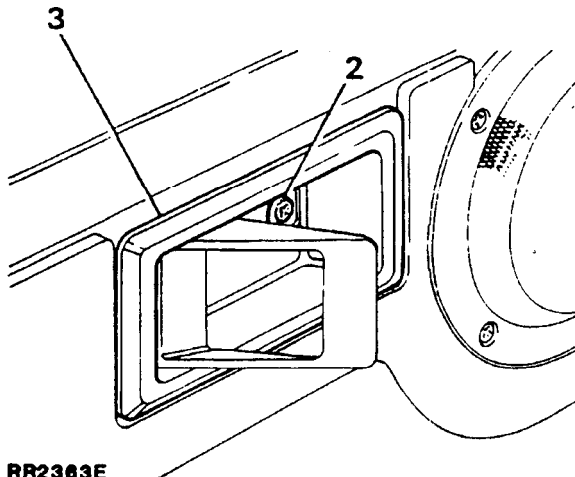

4. Carefully pry the sill locking button surround from the trim panel.

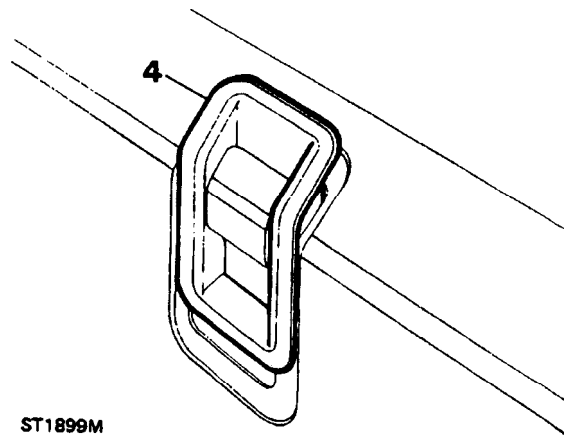

5. Remove the two finisher buttons from the bottom of the door pull pocket to reveal the securing screws.
6. Remove the screws and withdraw the pocket from the trim panel.

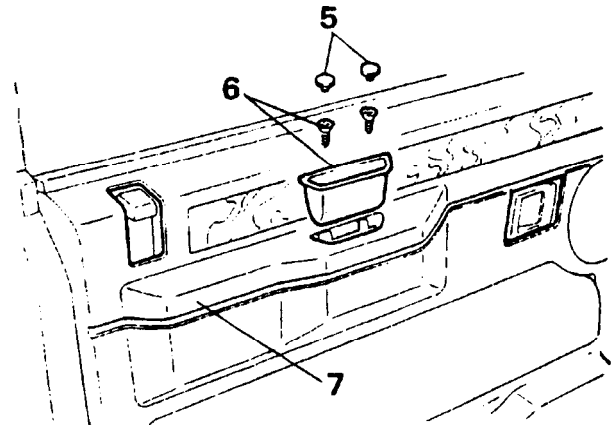

7. Using a taped screwdriver, carefully pry the trim panel away from the door.

**NOTE:** Support the trim panel while the speaker leads are disconnected.

8. If necessary the stowage bin front panel can be removed by releasing the screws at the rear of the trim panel.

Refitting

9. Reverse the removal procedure.

Continued

## FRONT DOOR LOCK, OUTSIDE AND INSIDE DOOR RELEASE HANDLES

## Remove and refit

## Removing

1. Remove the interior door release handle bezel and sill locking button bezel.
2. Remove the two screws from the bottom of the door pull pocket remove the pocket and prise the door trim panel from the door. Disconnect the electrical leads to the door speaker and remove the plastic vapor barrier sheet.  
Remove the window lift motor. (Refer to the electrical section in main Workshop Manual).
4. Remove the door glass and regulator. (Refer to door glass and regulator remove and refit in main Workshop Manual).
5. Remove the door lock actuator. (Refer to electrical section in main Workshop Manual).
6. Disconnect the control rod from the key operated lock by releasing the metal clip at the bottom of the rod.
7. Disconnect the control rod from the outside door release handle by pulling it out of the plastic ferrule.
8. Disconnect the control rod connector between the inside door release handle and the door lock by releasing the metal clip and pulling one of the control rods out of the plastic connecting block. This is accessible through the small centre cut - out in the door panel. (The control rod also passes through a guide bracket on the inside of the inner door panel).
9. From inside the door panel push out the small pin which secures the quadrant to the inner door panel. Push the quadrant out of the panel.
10. Remove the two screws securing the sill locking button to the door. manouver the sill button and remove it from the control rod.
11. Release the door lock by removing the two countersunk screws from the door edge and the single screw with shakeproof washer on the inner door panel.

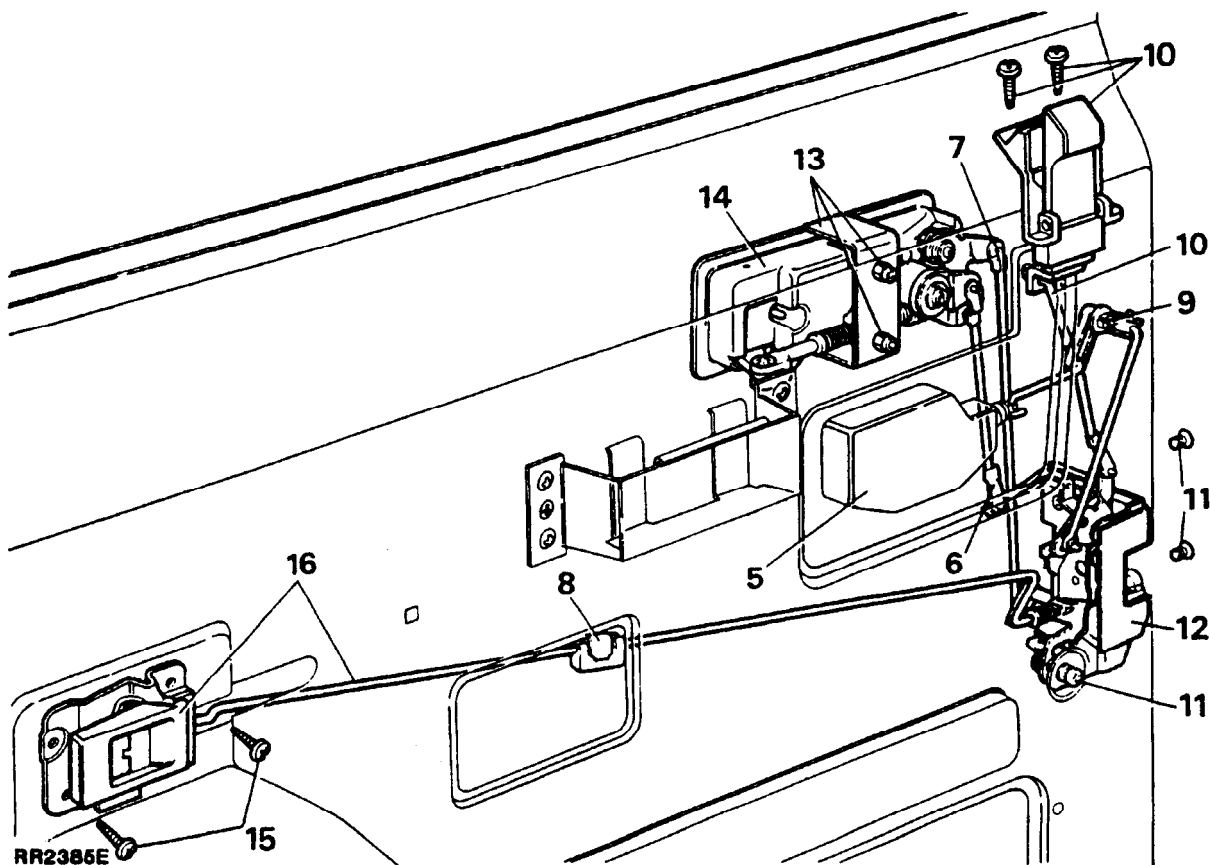

12. Withdraw the lock through the lower rear cut-out on the inner door panel.

NOTE: If necessary the following items can be removed.

13. Remove the two nuts (with shakeproof washers) and retaining bracket securing the outside release handle to the outer door panel, accessible through the upper rear cut-out on the inner door panel.
14. Carefully detach the door release handle from the outer door panel.
15. Remove the two screws securing the inside door release handle to the inner door panel.
16. Withdraw the handle from its location with half of the connecting rod attached.

Refitting

17. Reverse the removal procedure items 1 to 16.

NOTE: When refitting the door glass frame, ensure that it is positioned to suit the door opening before fully tightening the frame securing bolts.

HEATED FRONT DOOR LOCK ASSEMBLY • 1991 MODEL YEAR

Remove and refit

Remove

1. Disconnect battery negative lead.
2. Remove outside front door handle assembly.

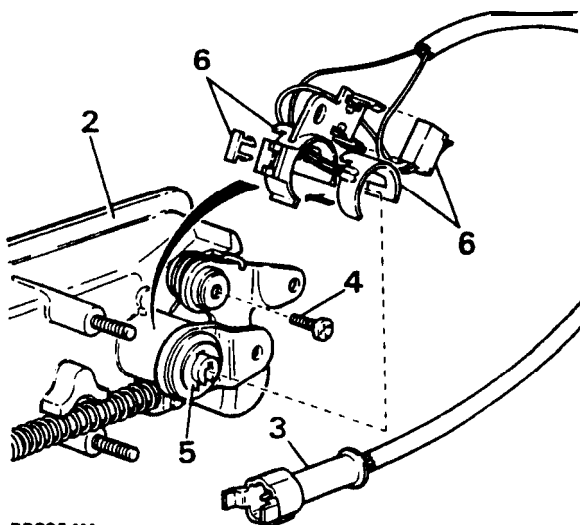

RR2954M

3. Disconnect the heaters electrical wiring at the multiplug.
4. Remove heater retaining bracket screw.
5. Remove 'C' clip and colored cam link from end of barrel assembly.

Caution: Ensure the loose barrel assembly remains in position, to avoid components falling apart.

6. Remove heater retaining bracket, complete with de-icing element, switch and wiring assembly.

Refit

7. Hold de-icing element in position and fit heater retaining bracket assembly.
8. Reverse removal instructions 1 to 5.
9. Recode the radio.

ADJUSTMENT - FRONT DOOR LOCK AND HANDLE ASSEMBLY

Inside door release handle to lock

1. Refit the inside door release handle bezel before any adjustment is made, allowing the handle to be set for the correct operating position.
2. Rotate the spring tensioned nyloc nut at the door lock clockwise or counter-clockwise to shorten or extend the operating length of the rod as required.

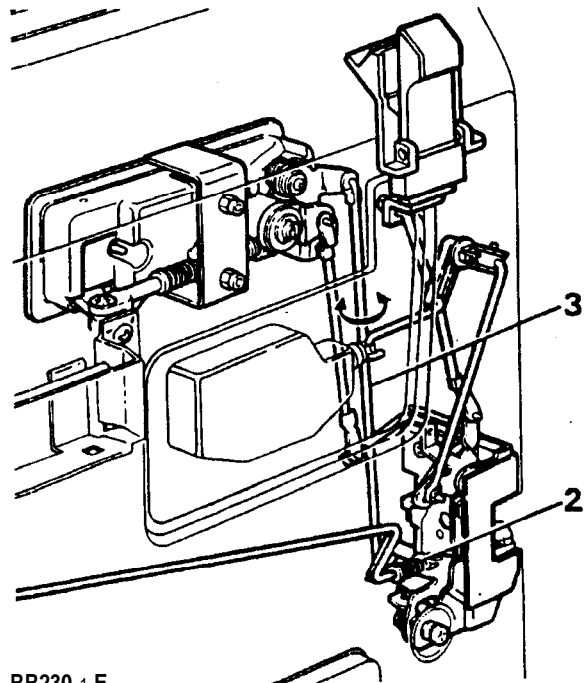

RR230 1 E

**Outside door release handle to lock**

3. Disconnect the connecting rod at the rear of the outer door release handle by releasing the the rod from the plastic ferrule, rotate the rod clockwise or counter - clockwise to shorten or extend the operating length, refit the rod to the ferrule.

**NOTE:** Door release should occur before the total handle movement is made to provide a small overthrow movement.

**REAR DOOR - TRIM PANEL****Remove and refit****Removing**

1. Disconnect the battery negative terminal.
2. Remove the screw securing the handle surround.
3. Remove the surround.

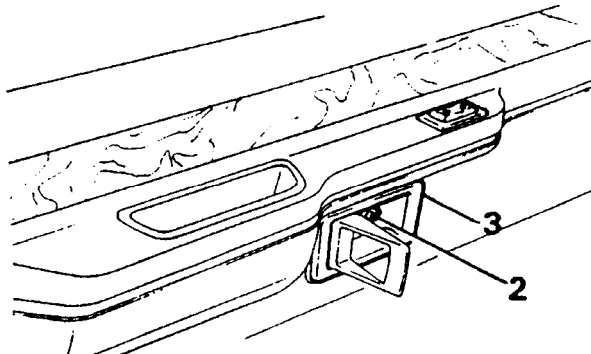
**RR2478E**

4. Pry the door locking button surround from the trim panel.

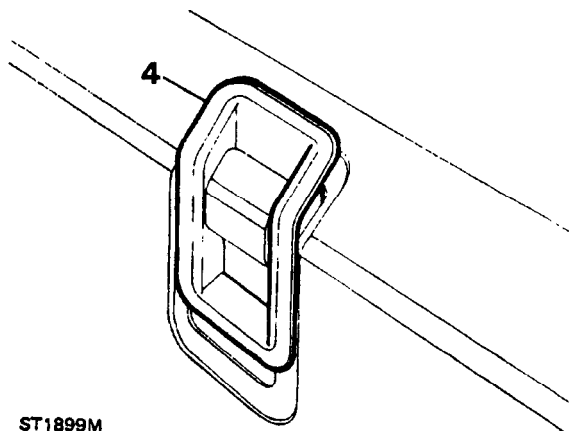
**ST1899M**

5. Remove the two finisher buttons from the bottom of the door pull pocket to reveal the securing screws.
6. Remove the screws and withdraw the pocket from the trim panel.
7. Using a taped screwdriver, carefully pry the trim panel away from the door.
8. Disconnect the electrical plug from the window lift switch.
9. Remove the window lift switch by pushing from behind the trim panel.

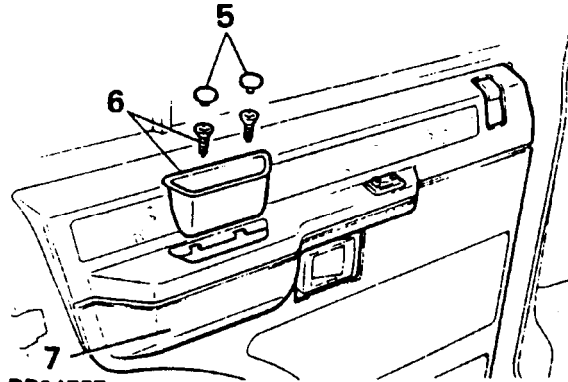
**RR2477E****Refitting**

10. Reverse the removal instructions.



REAR DOOR LOCK, OUTSIDE AND INSIDE DOOR RELEASE HANDLES

Remove and refit

Removing

7. Ensure the window is fully closed position and disconnect the battery negative terminal.
2. Remove the interior door handle surround, pry the window lift switch from the trim panel and disconnect the electrical multi - plug.
3. Pry the sill button from the trim panel.
4. Remove the two screws from the bottom of the door pull pocket accessible after removing the two buttons and detach the trim panel from the door panel. Remove the plastic vapor barrier sheet.
5. Disconnect the control rod from the inside door release handle by pulling the rod out of its location at the door lock.
6. Disconnect the sill locking control rod from the door lock by releasing the metal clip.
7. Disconnect the control rod from the outside door release handle by pulling it out of the plastic ferrule.

8. Release the door lock by removing the two countersunk screws from the door edge and the single screw (with shakeproof washer) on the inside of the door. Retrieve any spacing washers which may be fitted between the inner door panel and lock.
9. Withdraw the lock through the upper rear opening in the inner door panel.

**NOTE: If necessary the following items can also be removed.**

10. Remove the two nuts (with shakeproof washers) and retaining bracket securing the outside door release handle which are accessible through the upper rear cut - out on the inner door panel.
71. Carefully detach the outside door release handle from the outer door panel.
72. Remove the two screws (with plain washers) securing the inside door release handle to the inner door panel.
13. Withdraw the handle from its location with the connecting rod attached.

Continued

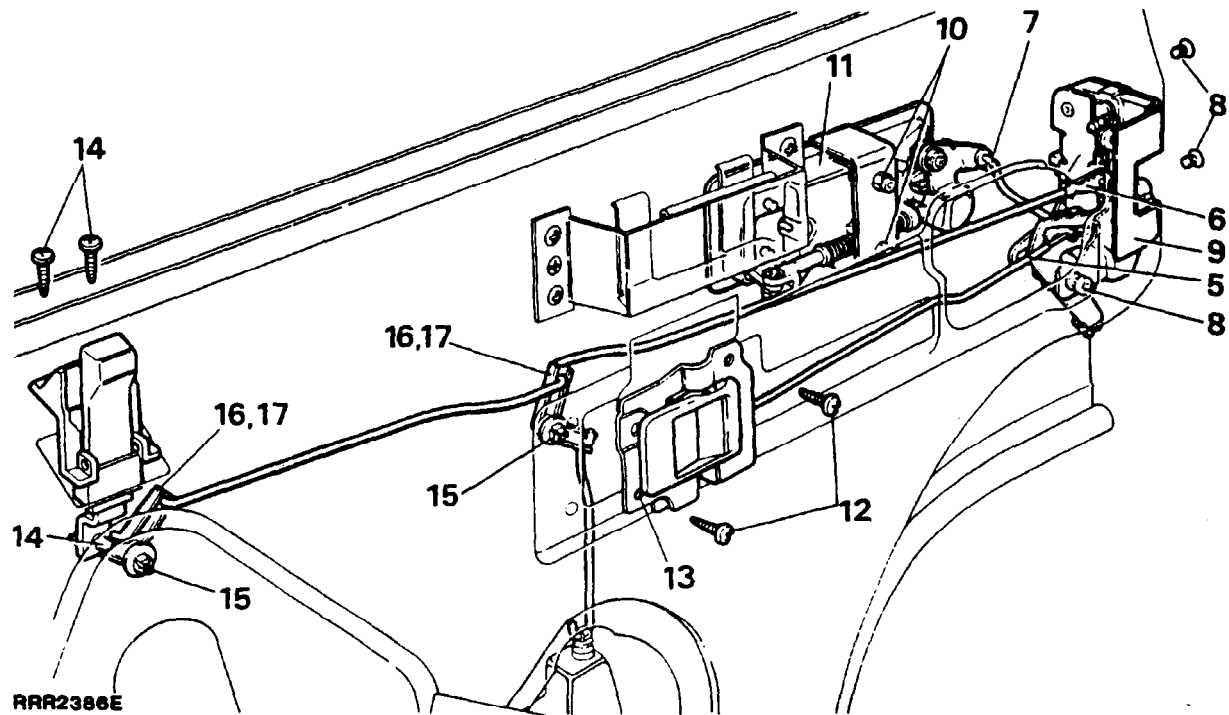

14. Remove the two screws securing the sill locking button to the inner door panel and detach the sill button from the bellcrank.

#### Sill locking bellcranks

15. Using a small screwdriver, or 3.175 mm (0.125 in) diameter rod, press the plastic locking pins through the respective square inserts in the inner door panel, until they can be retrieved from inside the door.
16. Release the bellcranks from the inner door panel and unhook the respective connecting rods.
17. Withdraw the bellcranks from the inner door panel.

**NOTE:** When refitting the bellcranks the locking pins are entered into the square insert from outside and pressed in flush.

#### Refitting

18. Reverse the removal procedure items 1 to 17.

**NOTE:** When refitting the door glass frame, ensure that it is positioned to suit the door opening before fully tightening the frame securing bolts.

#### ADJUSTMENT - REAR DOOR LOCK AND HANDLE ASSEMBLY - 4 Door models

##### Outside door release handle to lock

1. Disconnect the short offset connecting rod at the rear of the door outer release handle, rotate the rod clockwise or counter-clockwise to shorten or extend the operating length of the rod as required.

**NOTE:** Door release should occur before the total handle movement is made to provide a small overthrow movement.

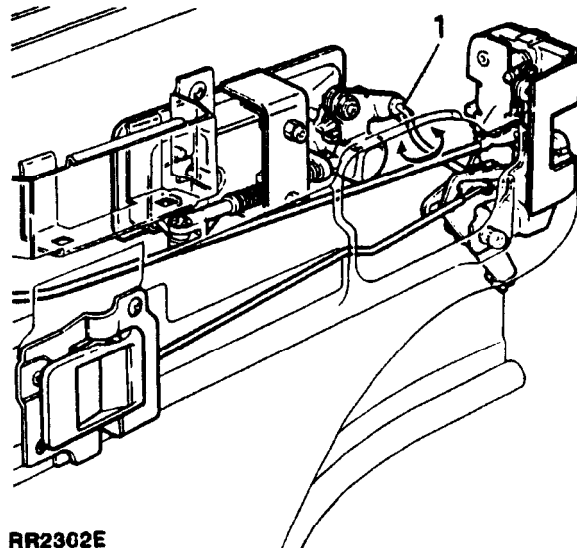

**ASYMMETRIC SPLIT REAR SEAT - LOCKING MECHANISM**

NOTE: 1989 Model Year vehicles have a revised seat locking mechanism which incorporates a push button release in place of a finger lift button. The revised latch and striker give the seat an improved positive location.

**Remove and refit**

**Removing**

1. Depress the seat release button and fold the seat back forward.
2. Unscrew and remove the seat release button.
3. Pry out the two trim buttons securing the trim covering to the latch tower.
4. Manoeuvre the trim covering from the tower.
5. Remove the three screws securing the latch to the tower, noting that access to the single screw is gained through the hole in the front of the tower.
6. Retrieve the latch from the opening at the rear of the tower. If necessary retrieve the single screw.
7. The operating rod can be removed from the latch by releasing the rod at the plastic clip.

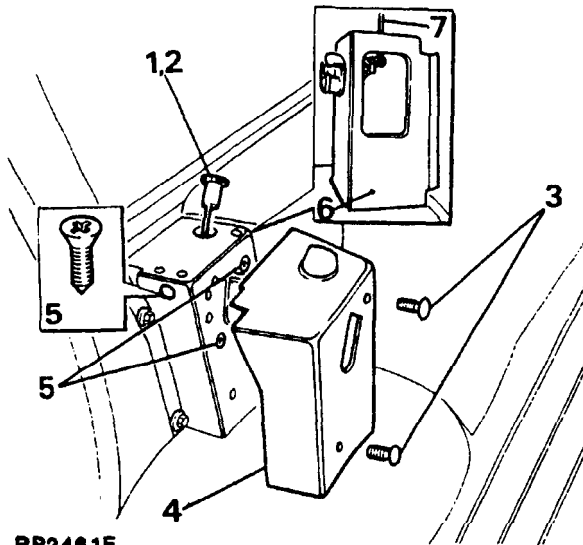

**Refitting**

8. Refitting is a reversal of the removal procedure noting that when the seat release button is screwed onto the operating rod there must be a gap of 5 - 8 mm (0.196 - 0.312 inch) between the head of the button and lip of the trim covering after the button has been depressed.

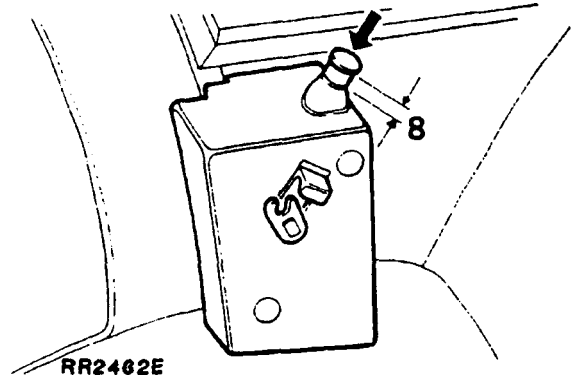

Continued

## ENGINE UNDERTRAY

Removal of engine under-tray fitted to 1989 model year vehicles is necessary when changing the oil filter. Removal will also facilitate attention to engine, cooling system and steering components.

Remove and refit

**Removing**

1. Disconnect battery negative lead.
2. Remove three screws, securing under-tray to spoiler.
3. Remove two screws, one each side, securing rear of under-tray to chassis mounting brackets.
4. Remove under-tray by carefully flexing to clear rear mountings.
5. Removal of one or both rear mounting brackets may be necessary, for example, when removing steering box. Remove the nut and washer from the chassis bolt.
6. Withdraw the undertray mounting bracket.

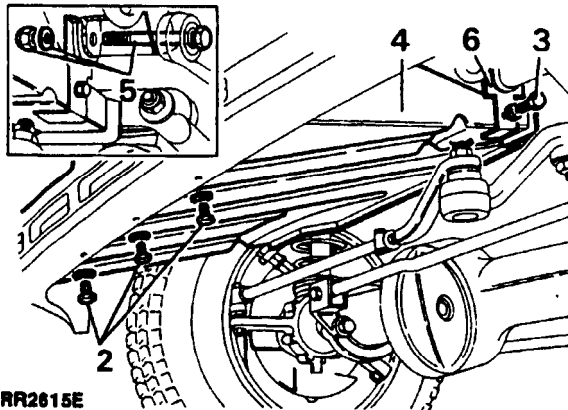
**Refitting**

7. Reverse the removal procedure.
-

FRONT DOOR

Remove, refit and adjust.

Removing

1. Disconnect the battery negative lead.
2. Open the door to be removed.
3. Remove the trim panel from side of footwell by carefully levering under the trim and prising out the two plastic clips.

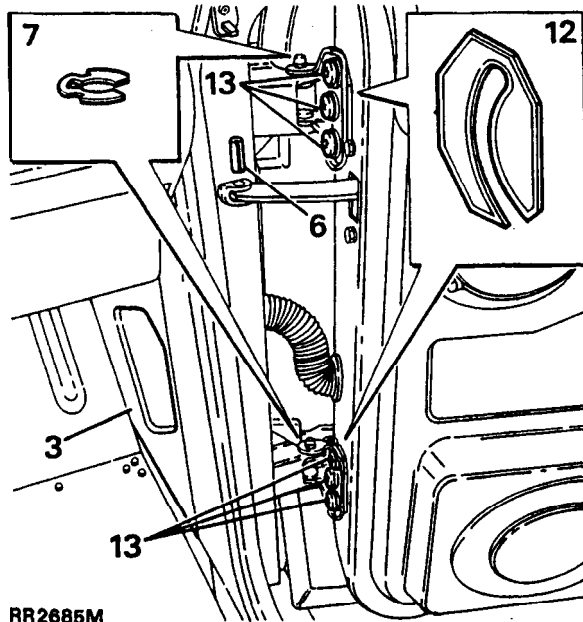

4. Locate and disconnect all door wiring plugs.
5. Disengage the grommets either side of 'A' post and feed wiring out.
6. Drive out the roll pin from the door check link.
7. Remove 'C' clips from grooves in hinge pins.

**WARNING: Instruction 8. MUST BE carried out with assistance.**

8. Carefully lift the opened door off the hinge pins.

Refitting

9. Reverse the removal procedure. Renew the 'C' clips if worn or distorted.
10. With door fully open reconnect wiring plugs ensuring they are located above the trim panel.
11. Check the operation of the door and lock. If necessary, adjust the door and striker plate.

Adjusting

12. Adjust the door by means of shims between the hinge and door to move the door forward or rearward in the opening.
13. Loosen the six Torx screws securing the hinges to the door to adjust the door up and down or in and out of the opening. Retighten the screws to the specified torque values.
14. The door lock striker can be adjusted by loosening the striker and moving it in the appropriate direction or adding and subtracting spacing washers between the striker and 'B' post.

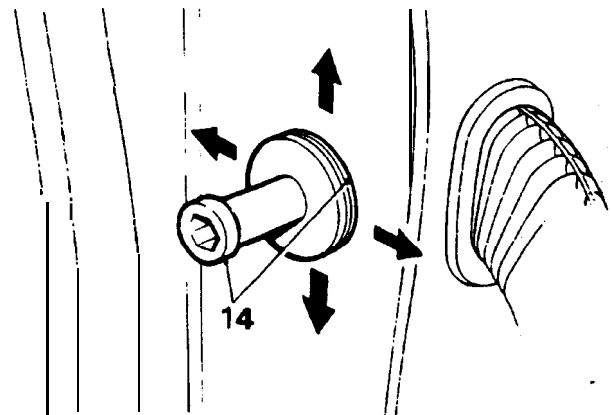

15. Note: If it is necessary to remove hinges from 'A' post they should be refitted in exactly the same position using the same thickness of shims.

REAR PASSENGER DOOR

Remove, refit and adjust.

Removing

1. Disconnect the battery negative lead.
2. Remove wiring grommet from the 'B' post.
3. Withdraw the door wiring plugs from the 'B' post and disconnect them.
4. Remove the two bolts securing the check strap to 'B' post.

- Remove 'C' clips from grooves in the hinge pins.

**WARNING:** Instruction 6. **MUST BE** carried out with assistance.

- Carefully lift the opened door off the hinge pins.

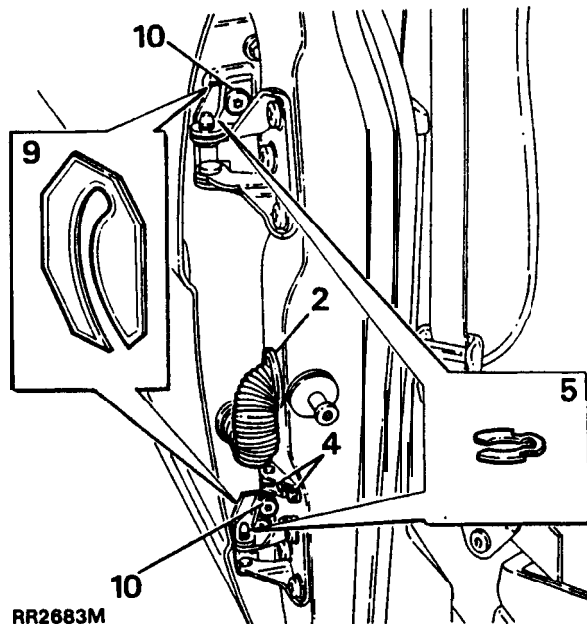

**Refitting**

- Reverse the removal procedure. Renew 'C' clips if worn or distorted.
- Check the operation of the door and lock. If necessary, adjust the door and striker plate.

**Adjusting**

- Adjust the door by means of shims between the hinge and door to move the door forward or rearward in the opening.
- Loosen the six Torx screws securing the hinges to the door to adjust the door up and down or in and out of the opening. Retighten the screws to the specified torque values.
- Adjustment to the door striker is identical to front doors.
- Note: If it is necessary to remove hinges from 'B' post they should be refitted in exactly the same position using the same thickness of shims.

**COWL PANEL**

**Remove and Refit**

**Removing**

- Disconnect the battery negative lead and remove the hood.
- Remove the wiper arms and two nuts securing the wheel boxes to the cowl panel and remove the two sealing rubbers.
- Remove the two cross-head screws retaining the panel to the 'A' post mounting brackets located above the front door hinges.

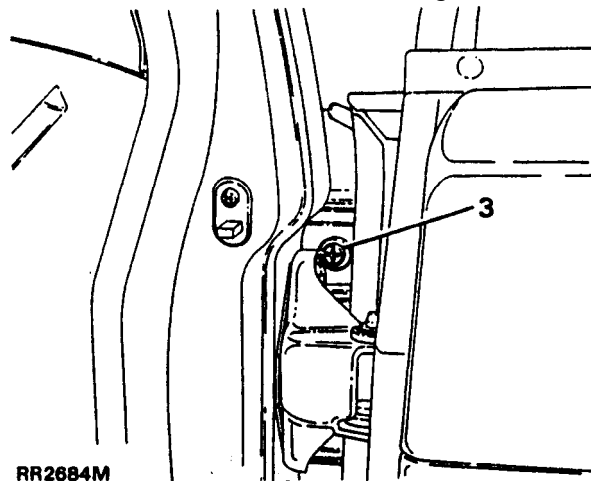

- Remove the nine cross-head screws securing the front of the cowl panel.
- Remove the four bolts with spring and plain washers securing cowl panel to front fenders accessible from the front of the cowl panel.

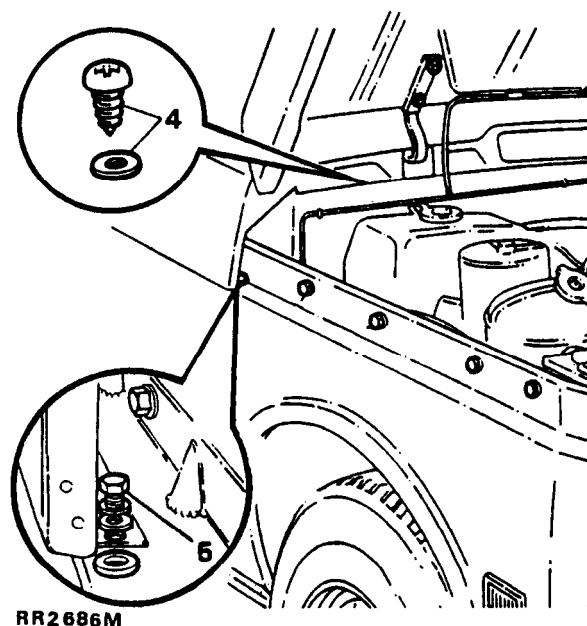

6. With assistance place a tube over each of the hinges and lower to enable the cowl panel to be fed over the hinges, gradually return the hinges to their upright position.

**WARNING:** Gradually let the torsion bar spring tension return the hinges to their upright position to prevent the possibility of personal injury or damage to the vehicle.

**Refitting**

7. Reverse the cowl panel removal instruction.
8. Using a soft blunt implement ease the windscreen rubber up onto the top of the cowl panel.

**FRONT WHEEL ARCH LINER**

**Remove and refit**

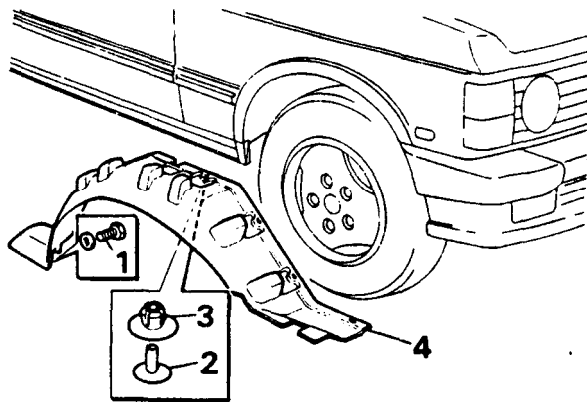

RR2711M

**Remove**

1. Remove the bolt and washer securing the rear lower edge of the liner.
2. Carefully pry out the centre studs of the eight plastic clips spaced around the liner.
3. Carefully pry out the plastic clips.
4. Remove the liner.

**Refit**

5. Reverse the removal procedure renew the clips as necessary.

**SILL FINISHER**

**Remove and refit**

**Remove**

1. Remove nut and washer from underneath the front of sill finisher.
2. Using a drift tap through the centre piece of the ten 'Rocut' fixing rivets.
3. Carefully pry out the Rocut rivets and remove the sill finisher.

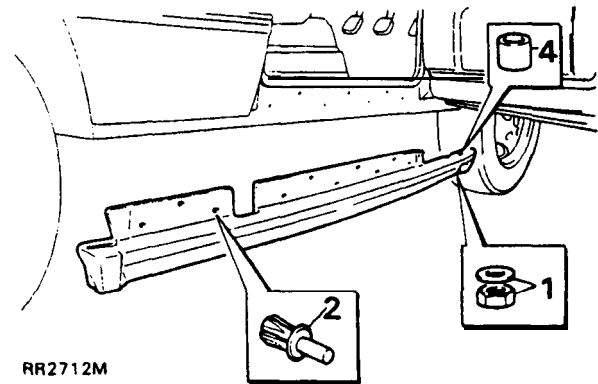

RR2712M

**Refit**

4. Reverse the removal procedure, renewing the Rocut rivets and ensuring the metal tube insert is refitted into the sill finisher where the bolt goes through.

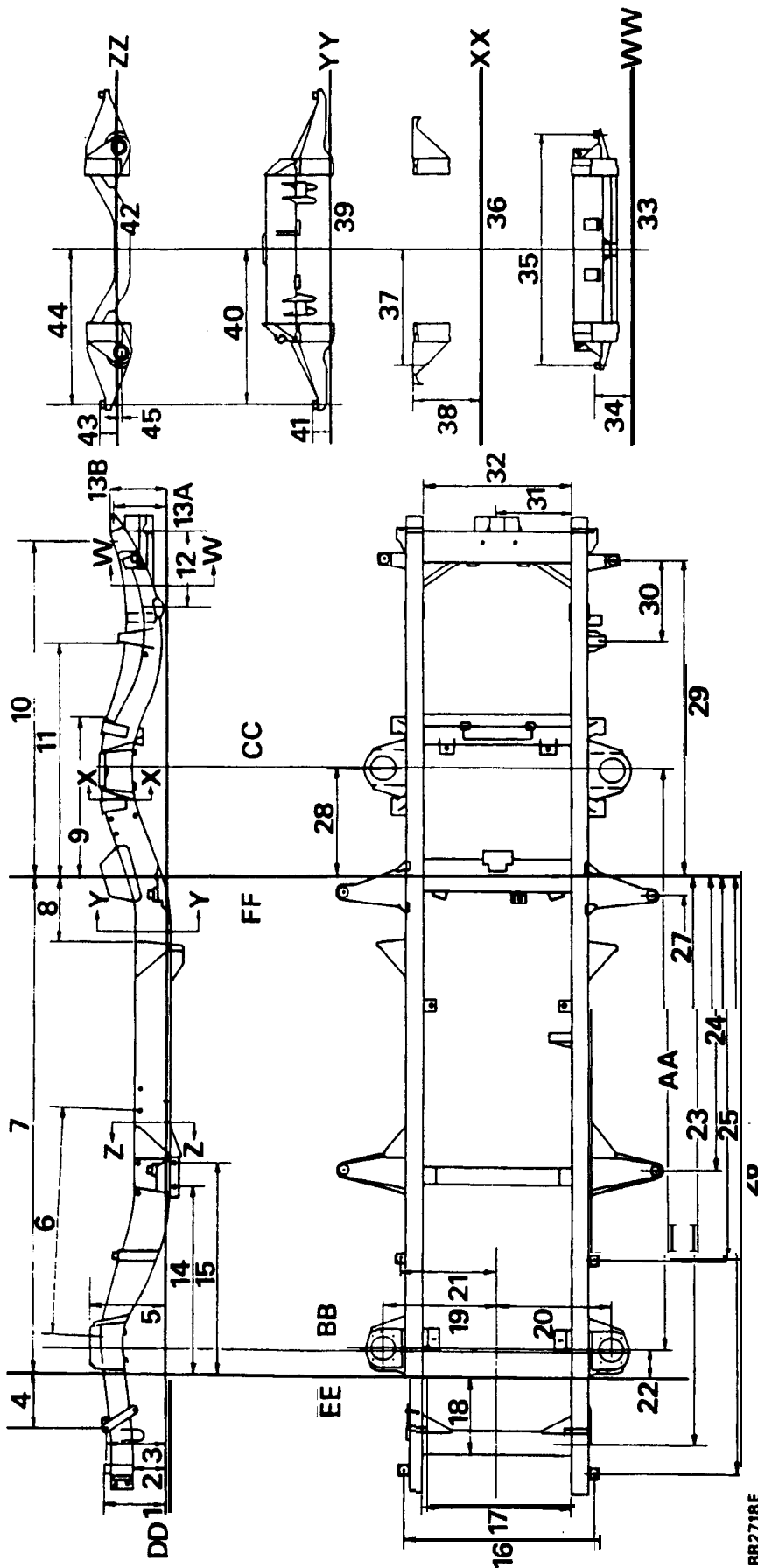



CHASSIS FRAME • 1990 Model Year

Alignment check • **RR2718E**

| Diagram reference                                 | millimeters          | inches              |
|---|----------------------|---------------------|
| <b>AA Wheelbase reference dimension</b>           | 2540,00              | 100. 0              |
| <b>BB Centre line of front axle</b>               |                      |                     |
| <b>c c Centre line of rear axle</b>               |                      |                     |
| <b>DD Frame datum line</b>                        |                      |                     |
| <b>EE Side member datum line</b>                  |                      |                     |
| <b>FF Datum line</b>                              |                      |                     |
|   | 264, 525 $\pm$ 1,27  | 10. 400 $\pm$ .050  |
| 2 <b>Frame datum to underside of cross-member</b> | 150,80               | 5. 937              |
| 3   | 266,70 $\pm$ 2. 54   | 10. 500 $\pm$ .100  |
| 4   | 237. 74 $\pm$ 1,27   | 9. 360 $\pm$ .050   |
| 5   | 327. 81 $\pm$ 2. 54  | 12. 906 $\pm$ .100  |
| 6   | 979,94               | 38. 58              |
| 7   | 2179,73 $\pm$ 2,54   | 85. 816 $\pm$ .100  |
| 8   | 291,74 $\pm$ 2,54    | 11. 486 $\pm$ .100  |
| 9   | 707,96 $\pm$ 2,54    | 27. 872 $\pm$ .100  |
| 10  | 1468,49 $\pm$ 2. 54  | 57. 815 $\pm$ .100  |
| 11  | 1025,27 $\pm$ 2,54   | 40. 36 $\pm$ .100   |
| 12  | 338,84 $\pm$ 2,54    | 13. 34 $\pm$ .100   |
| 13A   | 222. 25 $\pm$ 2. 54  | 8. 750 $\pm$ .100   |
| 13B   | 252. 904 $\pm$ 2. 54 | 9. 960 $\pm$ .100   |
| 14 <b>Reference dimension</b>                     | 824,92               | 32. 477             |
| 15 <b>To face of boss (both sides)</b>            | 935,43 $\pm$ 2,54    | 36. 828 $\pm$ .100  |
| 16  | 838,2 $\pm$ 0,38     | 33. 000 $\pm$ .015  |
| 17 <b>Check figure</b>                            | 630. 94 $\pm$ 1,27   | 24. 840 $\pm$ .050  |
| 18  | 344,17 $\pm$ 1, 27   | 13. 550 $\pm$ .050  |
| 19  | 485,77 $\pm$ 2,54    | 19. 125 $\pm$ .100  |
| 20  | 405. 77 $\pm$ 2,54   | 19. 125 $\pm$ .100  |
| 21  | 828,68 $\pm$ 0,38    | 32. 625 $\pm$ .015  |
| 22  | 129. 03 $\pm$ 2,54   | 5. 080 $\pm$ .100   |
| 23  | 2479. 45 $\pm$ 0,25  | 97. 616 $\pm$ .010  |
| 24  | 1290,34 $\pm$ 0,38   | 50. 800 $\pm$ .015  |
| 25  | 1657,04 $\pm$ 0,38   | 65. 238 $\pm$ .015  |
| 26  | 2598,44 $\pm$ 0,38   | 102. 301 $\pm$ .015 |
| 27  | 79,09 $\pm$ 0,38     | 3. 114 $\pm$ .015   |
| 28  | 465,48 $\pm$ 2,54    | 18. 326 $\pm$ .100  |
| 29  | 1398,88 $\pm$ 0,38   | 55. 074 $\pm$ .015  |
| 30  | 368,30 $\pm$ 2,54    | 14. 50 $\pm$ .100   |
| 31 <b>Reference dimension</b>                     | 317,50               | 12. 50              |
| 32 <b>Reference dimension</b>                     | 635, 00              | 25. 00              |

CHASSIS FRAME

| Diagram reference             | millimeters       | inches            |
|-------------------------------|-------------------|-------------------|
| <b>SECTION W - W</b>          |                   |                   |
| <b>33 Frame datum line DD</b> |                   |                   |
| 34                            | 155.91 $\pm$ 1,27 | 6.14 $\pm$ .050   |
| 35                            | 990,6 $\pm$ 0,38  | 39.00 $\pm$ .015  |
| <b>SECTION X - X</b>          |                   |                   |
| <b>36 Frame datum line DD</b> |                   |                   |
| 37                            | 488,95 $\pm$ 2,54 | 19.250 $\pm$ .100 |
| 38                            | 295.27 $\pm$ 2,54 | 11.625 $\pm$ .100 |
| <b>SECTION Y - Y</b>          |                   |                   |
| <b>98 Frame datum line DD</b> |                   |                   |
| 40                            | 660,40 $\pm$ 0,25 | 26.00 $\pm$ .010  |
| 41                            | 80,39 $\pm$ 1,27  | 3.187 $\pm$ .050  |
| <b>SECTION Z - Z</b>          |                   |                   |
| <b>42 Frame datum line DD</b> |                   |                   |
| 43                            | 80.39 $\pm$ 1,27  | 3.165 $\pm$ .050  |
| 44                            | 660,40 $\pm$ 0.25 | 26.000 $\pm$ .010 |
| 45                            | 9.53 $\pm$ 2,54   | 0.375 $\pm$ .100  |

**GLASS SUNROOF 1991 MODEL YEAR**

**Operation**

The sunroof operates in a tilt and slide action controlled by a rocker switch near the interior lamp.

A drive motor and control unit is located behind the switch and interior lamp panel. The control units function is to stop the drive motor at the full tilt and slide positions.

The removal and refit of the sunroof assemblies shown can be carried out without removing the complete sunroof assembly.

**GLASS SUNROOF ASSEMBLY.**

**Remove refit and adjust**

**Remove**

1. Open the sunroof to the tilt position.
2. Remove the two mechanism covers. Slide rearwards to disengage from their location and lift out.
3. Remove two screws from each side as shown.
4. Remove glass sunroof.

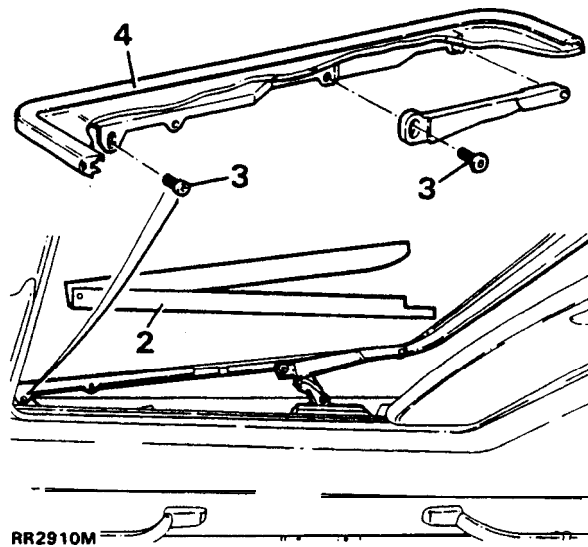

**Refit and adjust**

5. Replace the glass sunroof
6. Fit the four screws firmly but do not tighten.
7. Close the sunroof

8. Check the height of the sunroof panel against the roof aperture. The trimmed edge of the glass sunroof should stand approximately 1mm proud of the roof aperture.
9. Adjust by releasing the four screws and moving the sunroof up or down as required. Tighten the screws.
10. Fit the two mechanism covers.
11. Fully check the sunroof operates correctly.

**SUNROOF WIND DEFLECTOR ASSEMBLY**

**Remove, refit and adjust**

**Remove**

1. Open sunroof.
2. Remove the two screws accessed through the slot in the deflector
3. Remove the wind deflector assembly

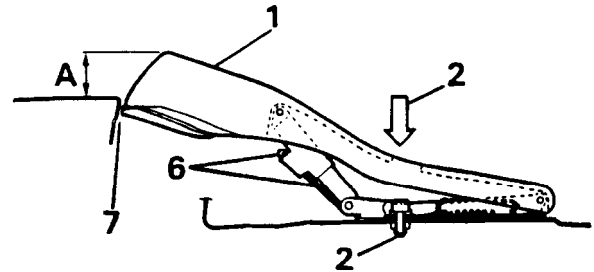

RR2909M

**Refit**

4. Replace the wind deflector assembly
5. Fit the two screws firmly but do not tighten.

**Adjust**

**Note:** Adjustment and attachment of the deflector is by the same two screws.

6. Adjust the wind deflector rearwards or forwards into the position shown. At the same time adjust the height A' to 20mm by moving the slotted metal strip rearwards or forwards. Tighten the two screws.
7. Ensure the deflector does not catch the front edge of the roof aperture when operated.
8. On completion fully check that the sunroof operates correctly.

**Manual operation.**

If the sunroof fails to operate by electrical means the sunroof can be opened or closed manually with the key provided.

1. Remove the two turnbuckles to access the sunroof motor spindle located behind the switch plate.
2. Engage the key into the motor spindle and turn to open or close the sunroof panel.
3. On completion of manual operation the motor spindle **MUST BE TURNED BACK HALF A TURN TO ENSURE ENGAGEMENT TO THE ELECTRICAL DRIVE MOTOR.**

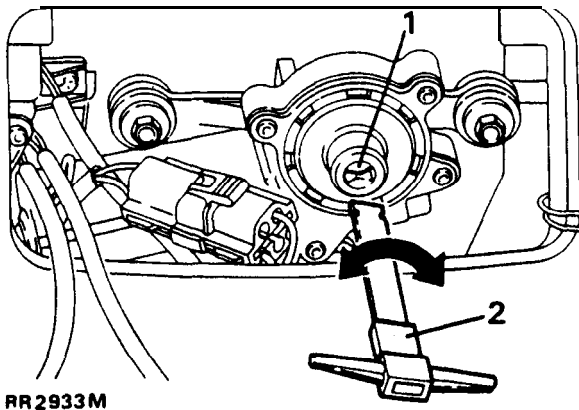

**MOTOR DRIVE ASSEMBLY AND CONTROL UNIT**

**NOTE:** The following servicing of the sunroof assembly can be carried out without removing the complete sunroof assembly.

**Remove and refit**

**Remove**

1. Fully close the sunroof then disconnect the battery negative terminal.
2. Turn to release the two turnbuckles to access the motor drive assembly and control unit, located behind the switchplate.
3. Remove the switchplate and disconnect the two multiplugs from the switch and courtesy light.

4. Release the front of the headlining sufficiently to access the motor drive assembly and control unit.
5. Disconnect the two multiplugs from the control unit to the motor drive unit and to the main harness.

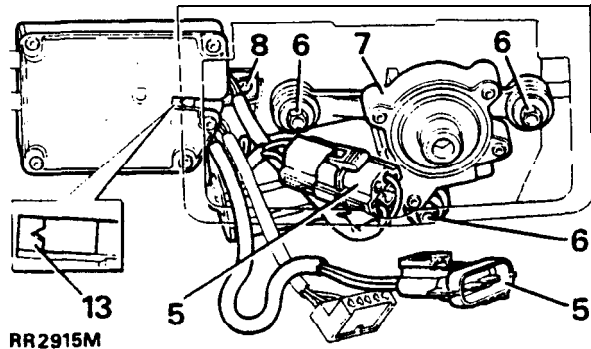

6. Remove the three screws securing the motor drive assembly.
7. Remove the motor drive assembly.
8. To remove the control unit undo the fixing screw. Lower then move the control box inwards to release from mounting.
9. Inspect the motor drive assembly and control unit for wear and damage, renew as necessary.

**Refit**

10. Refit the motor drive assembly ensuring the metal insert is fitted.

**CAUTION:**The motor drive assembly gear will not mesh correctly with the drive cables if the metal insert is **NOT** refitted.

11. Refit the control unit.
12. Check timing of the control unit to sunroof. A V-shaped notch should be visible through the slot in the control unit when the sunroof is in the fully closed position.
13. Reverse the removal instructions 2 to 5.
14. Fully check the sunroof operates correctly. Recode the radio.

GLASS SUNROOF COMPLETE ASSEMBLY

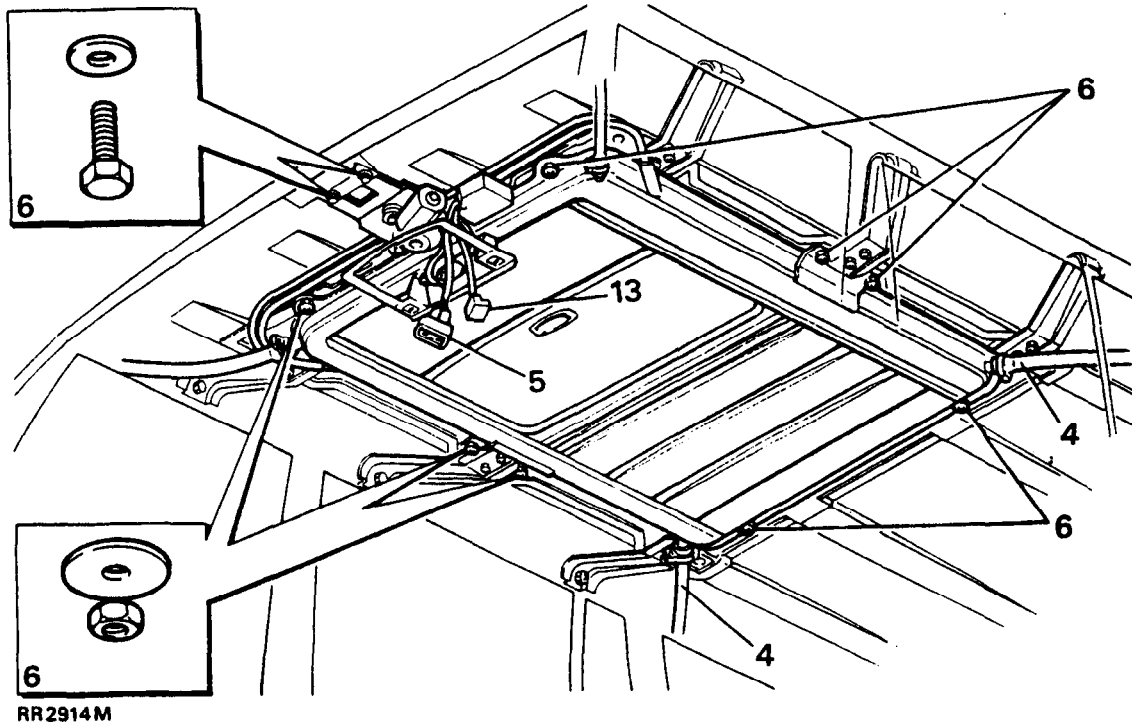

RR2914M

Remove and refit

Remove

1. Fully open the sunroof rearwards then disconnect the battery negative terminal.
2. Remove the switchplate and disconnect the two multiplugs from the switch and courtesy light
3. Remove the headlining completely from the vehicle
4. Remove the four clips and disconnect the drain tubes
5. Disconnect the multiplug from the control unit to the main harness.
6. With assistance remove the eight nuts and washers and two bolts. Lower the complete sunroof assembly to enable it to be removed through the rear of the vehicle.

Refit

7. Manually operate the sunroof to the fully closed position. On completion of manual operation the motor spindle MUST BE TURNED BACK HALF A TURN TO ENSURE ENGAGEMENT TO THE ELECTRICAL DRIVE MOTOR.

8. With assistance lift the complete sunroof assembly to the roof panel.
9. Locate and fit loosely the eight retaining nuts and washers and two bolts.
10. Ensure the closed sunroof now fits equally positioned in the roof panel aperture. Tighten the retaining nuts and bolts, recheck fit.
11. Reconnect the electrical multiplugs to the main harness and sunroof switch.
12. Fully check the sunroof operates correctly and leave in the open position.
13. Disconnect the sunroof switch
14. Fit and secure the drain tubes with retaining clips. Water test to ensure a watertight seal.
15. Fit the headlining and sunroof trim.
16. Reconnect electrical multiplugs to sunroof switch and interior light then fit switchplate.
17. Close glass sunroof and draw sunshade. Recode the radio.

SLIDE AND GUIDE CHANNEL ASSEMBLIES OR SUNSHADE PANEL.

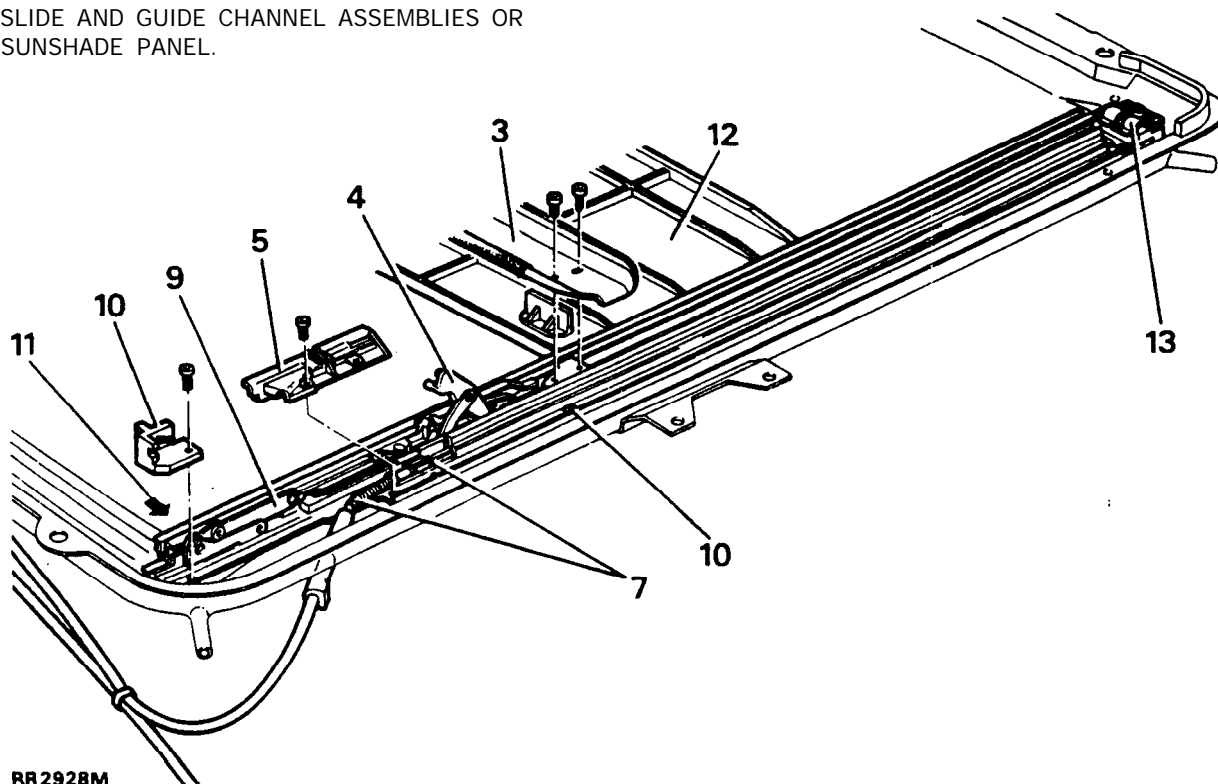

**Remove and refit**

**NOTE:** The following servicing of the sunroof assembly can be carried out without removing the complete sunroof assembly. The sunshade panel is removed by releasing, either the left or right slide and guide channel assembly, instructions 1. to 12.

**Remove**

1. Remove glass panel assembly.
2. Remove sunroof wind deflector assembly.
3. Remove rear crossmember drainchannel.
4. Move the tilt slide rearwards until the location cam is clear of the locator block.
5. Remove the locator block.

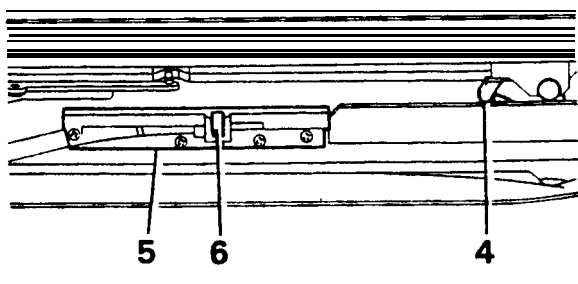

RR2929M

6. Move the tilt slide forwards until the location cam has reached the position it would normally locate into the locator block. Manually adjust the cam outwards to allow the tilt slide to pass and to attain the full tilt position.

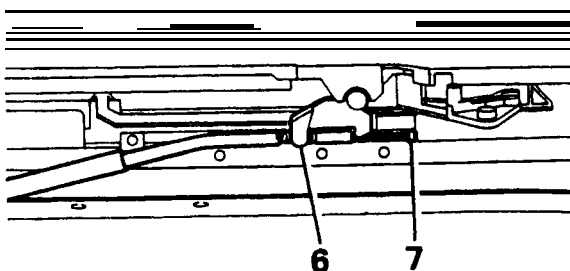

RR2930M

7. The drive cable end is now accessible. Disconnect drive cable from the slide assembly.
8. Push the tilt slide rear-wards reversing instruction 6.
9. Push complete slide assembly rearwards approximately 2".
10. Remove front end stop and the attaching screw from centre of guide channel.

11. Push guide channel assembly out sideways to release guide channel from the roof panel.
12. Slide the sunshade panel forward and lift out of runner to remove.

**Continue for removal of slide and guide channel assembly.**

13. With the aid of a flashlight directed between the roof panel and sunroof assembly. Observe for reassembly the guide channel rear spring fixing point.
14. Pull the guide channel forward to release from the rear spring fixing point. Remove the guide channel assembly

**Refit**

15. Reverse the removal instructions
16. Fully check the sunroof operates correctly.

2. To check timing of the control unit when the glass sunroof panel is removed. A V'shaped notch should be visible through the slot in the control unit when the sunroof tilt mechanism is in the position shown.

**TIMING OF CONTROL UNIT TO SUNROOF OPERATION.**

The timing of control unit to sunroof operation will be disturbed:-

If the sunroof position is altered when the control unit is removed.

Or the control unit is removed and the control unit gear is moved manually.

1. To check timing of the control unit to sunroof. A V'shaped notch should be visible through the slot in the control unit when the sunroof is in the fully closed position.

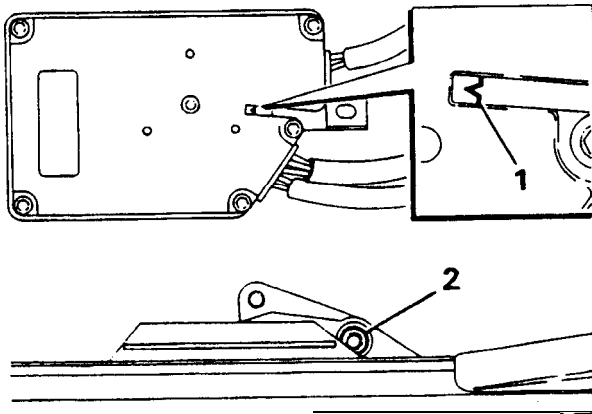

RR2927M

