

ABS FAULT DIAGNOSIS

If a fault has occurred, or has been identified by the ECU self diagnostic function and the ABS warning light is illuminated, the system and components must be checked to locate and rectify the fault, enabling the faulty component or harness to be replaced.

NOTE: If the warning lamp has indicated a fault in the system, and no fault code has been stored in the memory, the cause of the fault is:

- a) Failure in electrical supply
- b) Loss of hydraulic pressure
- c) Faulty pressure switch
- d) Bad ECU earth
- e) Faulty warning light relay
- f) System not fully charged before driving away
- g) ECU not connected

Before commencing the fault diagnosis procedure the following items must be checked:

1. Inspect all exposed cables for damage or abrasion.
2. Check earths on ABS system.
3. Battery - state of charge.
4. Fluid level in reservoir.
5. All ABS fuses and electrical connections.
6. Check hub end-float.

Fault rectification

1. The complete harness must be replaced if faults are found in the wiring harness.
2. DO NOT use unspecified cables or connectors, as this could jeopardise the safe function of the ABS.
3. DO NOT attempt to open the sealed 35 way connector to ECU.

Recommended equipment

Wabco diagnostic controller
- 446 300 300 0

FAULT DIAGNOSIS PROCEDURE

If diagnostic equipment is not available the following procedure can be carried out using the 'Blink Code' and a multi-meter. Faults are stored in the ECU memory in code form. The information can be retrieved by initiating and reading a series of flash and pause sequences on the ABS warning light.

Use of the blink code will determine the location of the fault prior to carrying out a multi-meter check, thus reducing multi-meter checking time.

Additionally the blink code can be used exclusively where a fault has occurred, and no other diagnostic equipment is available.

Recommended equipment

A female plug to fit the diagnostic plug, prewired to connect ECU pin 14 to earth by bridging the black/pink and black diagnostic plug wires.

To initiate the blink code carry out the following procedure:

1. Switch off ignition.
2. Remove the seat side trim to gain access to the ECU and relays, and on early vehicles the diagnostic plug. Unclip the access plate from the seat base front trim panel. Pull the blue diagnostic plug from its clip through the opening. Note that the diagnostic plug and fuse condition on early vehicles is shown in RR2742M.

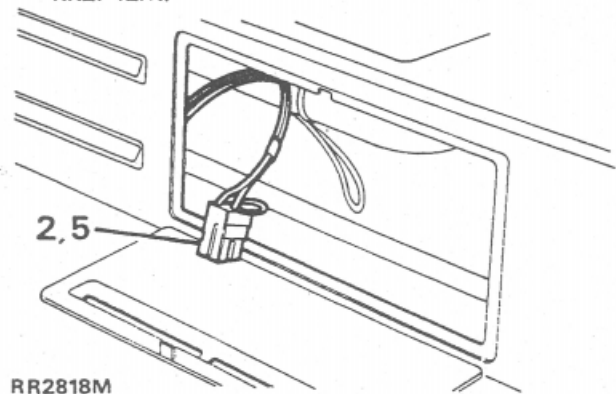

3. Remove the ABS warning light relay.

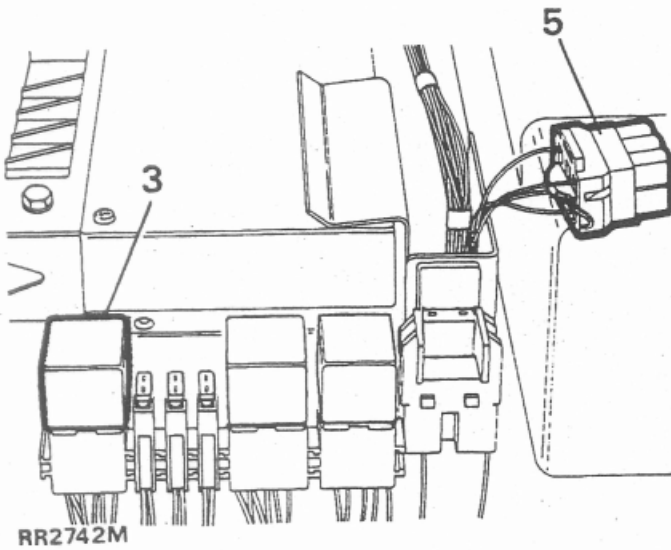

4. Switch on ignition, ABS warning light will illuminate.

5. Connect the prewired plug to the diagnostic plug.

6. Five seconds after connecting diagnostic plug the ABS warning light will extinguish, indicating the start of the blink code cycle.

7. **Start phase:** Observe the ABS warning light, the start phase consists of:

Pause - 2.5 secs (long)

Flash - 2.5 secs (long)

Pause - 2.5 secs (long)

Flash - 0.5 secs (short)

(A) shows flash sequence at start of blink cycle.

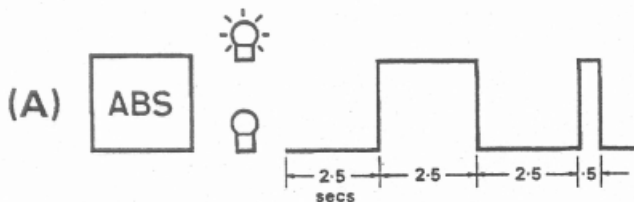

RR2719M

8. **First part of code number:** A pause of 2.5 secs precedes a series of short flashes. Count the flashes until the next long pause occurs, the number obtained is the first part of the code number.

9. **Second part of code number:** A pause of 2.5 secs occurs between first and second parts, before a second series of short flashes occurs. The number of flashes forms the second part of the code number.

(B) shows flash sequence for code number 3 - 3.

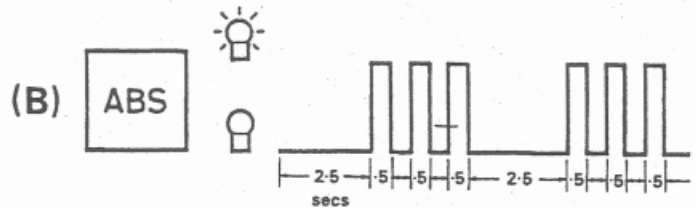

RR2720M

10. The sequence of start phase, first and second parts will continue until terminated by the operator, thus allowing the code obtained to be rechecked.

11. To terminate the sequence disconnect the prewired plug from the diagnostic plug. Wait for cycle to end before code will clear.

NOTE: Termination will clear the memory of that particular fault. Do not terminate the sequence if unsure of the code number.

12. The memory is capable of storing more than one fault. To search the memory, reconnect the diagnostic plug, and await the next start phase.

13. Repeat procedure until no further faults are stored in the memory. The memory is cleared when a long pause of 7.5 secs occurs after start phase.

WARNING: Be sure to reconnect the relay after completing test.

FAULT CODE /LOCATION	CIRCUIT DIAGRAM ITEM NUMBER	CAUSE/REMEDY
3-0 inlet front right 3-1 outlet front right 3-2 inlet front left 3-3 outlet front left 3-4 inlet rear right 3-5 outlet rear right 3-6 inlet rear left 3-7 outlet rear left 3-8 inlet isolating 3-9 outlet isolating	AB 23 IV AB 23 OV AB 22 IV AB 22 OV AB 25 IV AB 25 OV AB 24 IV AB 24 OV AB 21 IV AB 21 OV	<p>Open circuit in connection ECU to solenoid valve in booster, or inside ECU - possibly intermittent</p> <p>Carry out multi-meter check to: Wiring harness including connectors, booster</p> <p>Renew defective component, if all OK fit new ECU. Road test vehicle.</p>
4-0 inlet front right 4-1 outlet front right 4-2 inlet front left 4-3 outlet front left 4-4 inlet rear right 4-5 outlet rear right 4-6 inlet rear left 4-7 outlet rear left 4-8 inlet isolating 4-9 outlet isolating	AB 23 IV AB 23 OV AB 22 IV AB 22 OV AB 25 IV AB 25 OV AB 24 IV AB 24 OV AB 21 IV AB 21 OV	<p>Short circuit to ground in connection ECU to solenoid valve in booster - possibly intermittent</p> <p>Carry out multi-meter check to: Wiring harness including connectors, booster</p> <p>Renew defective component, if all OK fit new ECU. Road test vehicle.</p>
5-0 inlet front right 5-1 outlet front right 5-2 inlet front left 5-3 outlet front left 5-4 inlet rear right 5-5 outlet rear right 5-6 inlet rear left 5-7 outlet rear left 5-8 inlet isolating 5-9 outlet isolating	AB 23 IV AB 23 OV AB 22 IV AB 22 OV AB 25 IV AB 25 OV AB 24 IV AB 24 OV AB 21 IV AB 21 OV	<p>Short circuit to 12V in connection ECU to solenoid valve in booster - possibly intermittent</p> <p>Carry out multi-meter check to: Wiring harness including connectors, Booster Possible earth fault Renew defective component, if all OK fit new ECU. Road test vehicle</p>
6-0 inlet front right 6-1 outlet front right 6-2 inlet front left 6-3 outlet front left 6-4 inlet rear right 6-5 outlet rear right 6-6 inlet rear left 6-7 outlet rear left 6-8 inlet isolating 6-9 outlet isolating	AB 23 IV AB 23 OV AB 22 IV AB 22 OV AB 25 IV AB 25 OV AB 24 IV AB 24 OV AB 21 IV AB 21 OV	<p>Short circuit between two connections ECU to solenoid valve in booster - possibly intermittent</p> <p>NOTE: Failure codes for both affected valves will be stored</p> <p>Carry out multi-meter check to: a) Wiring harness, plug connectors, b) Booster</p> <p>Renew defective component, if all OK fit new ECU. Road test vehicle</p>

FAULT DIAGNOSIS

SYMPTOM	POSSIBLE CAUSE	CHECK	REMEDY
ABS warning light on	ABS electrical fault High sensor air gaps	Check ABS electrical circuit to identify fault	Change component if necessary Push in sensors
Both warning lights ON. Pedal travel and pedal force increased	No booster pressure (fluid loss) No booster pressure (pump not operating) Pump faulty	Check reservoir fluid level and inspect system for leaks Check electrical supply to pump	Rectify as necessary and refill reservoir Rectify electrical supply if necessary Change hydraulic pump
Both warning lights ON (no additional symptoms)	Malfunction of pressure switch	Disconnect pressure switch a) If light remains illuminated vehicle wiring faulty b) If lights extinguish pump defective	a) Test wiring change harness if necessary b) Change pump
Brake fluid warning light ON	Fluid loss Reservoir fluid level switch malfunction Pressure switch malfunction	Check reservoir fluid level and inspect system for leaks Check fluid level switch Check switch with pressure gauge a) If wiring faulty b) If switch faulty	Rectify leakage, refill reservoir Change reservoir cap/switch a) Replace harness b) Change hydraulic pump
Brake fluid warning light ON. Pedal travel increased, foot pressure normal	Fluid loss from hydrostatic circuit	Check reservoir level and inspect system for leaks	Rectify leakage and refill reservoir Rebleed as necessary

Fault Diagnosis - continued

SYMPTOM	POSSIBLE CAUSE	CHECK	REMEDY
Brake fluid warning light OFF. Pedal travel increased, foot pressure normal	Insufficient bleeding Master cylinder malfunction		Rebleed master cylinder circuit Change booster and bleed system
Hydraulic pump runs constantly	Fluid loss Pump non-return valve faulty	Check reservoir level and inspect system for leaks	Rectify leakage as necessary, refill reservoir Change hydraulic pump
Hydraulic pump runs constantly with warning lights OFF. Pedal travel normal.	Malfunction of pressure switch Relay switch malfunction	Disconnect pressure switch a) If pump stops b) If pump continues running	a) Change hydraulic pump b) Change relay or cable
Pedal can be moved downwards under constant pressure	Seal leaking in master cylinder Seal leaking in servo unit	Inspect system for leaks	Change booster unit Change booster unit